

NOTE

- 1. 端子テール部およびネイルの平坦度: 0.1mm MAX
TAIL AND NAIL COPLANARITY TO BE 0.1mm MAX
- 2 (極数/2) = 偶数 に適用
APPLY FOR (CIRCUIT SIZE/2) = EVEN.
- 3 関連製品・書類はSHEET5を参照ください
REFER TO SHEET 5 ABOUT RELATED PRODUCTS AND DOCUMENTS.

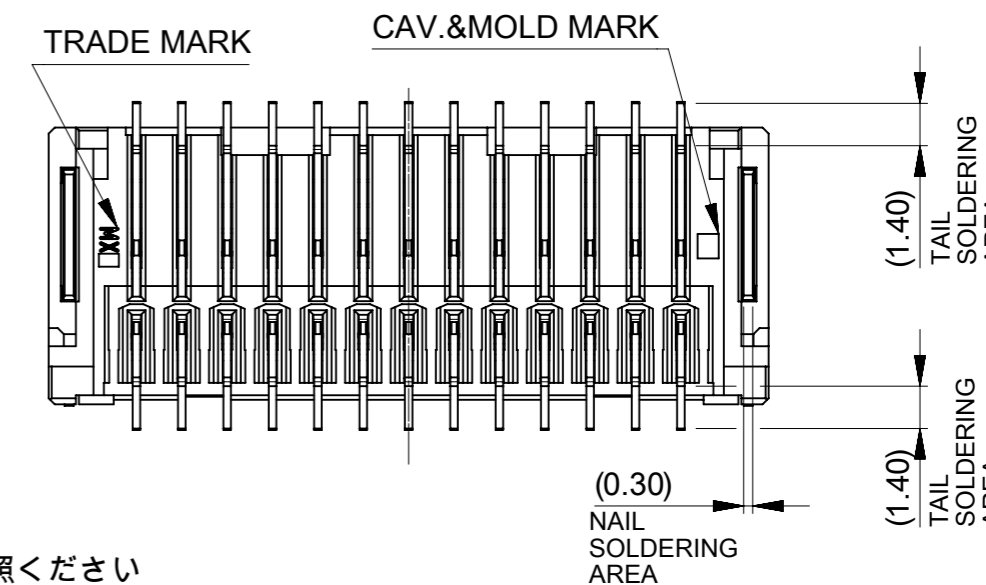
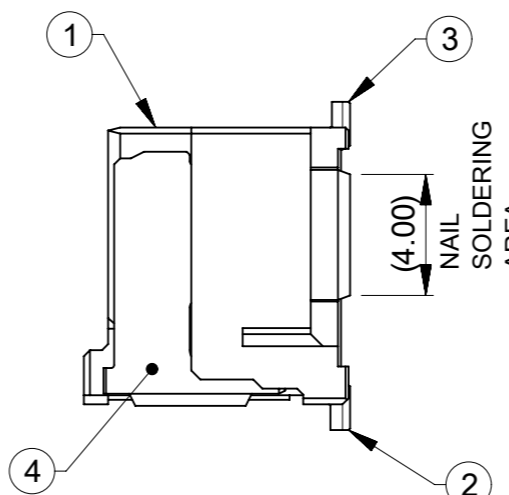
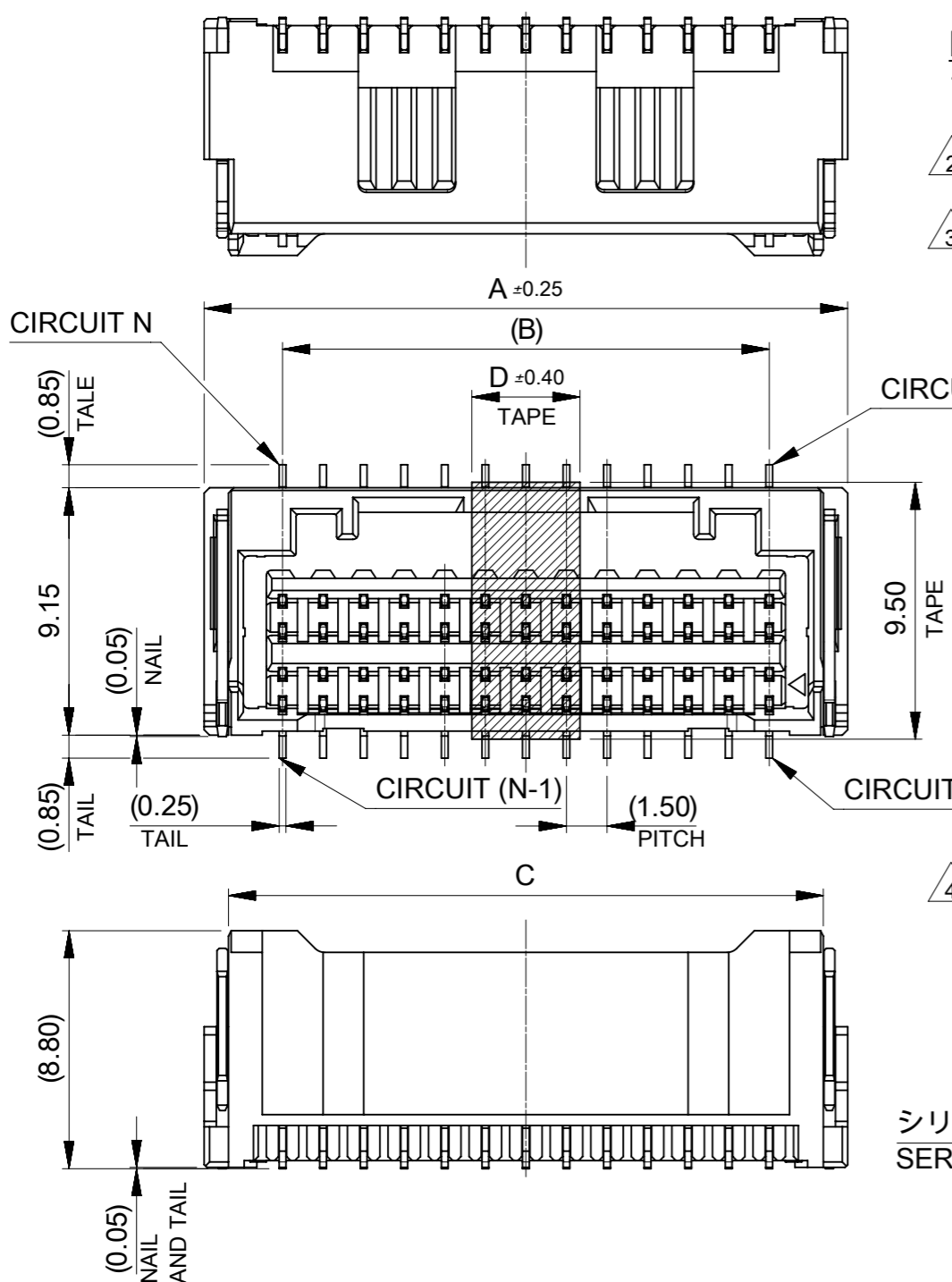
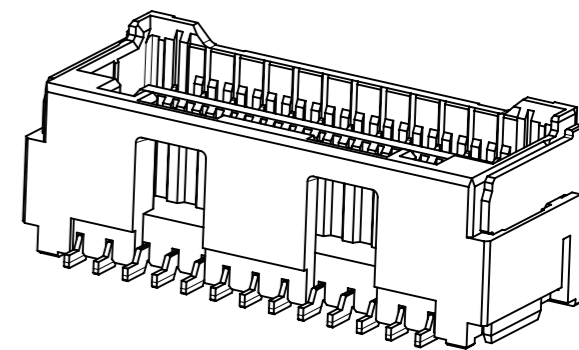

4 オーダー番号(製品番号): SHEET 6の製品一覧を参照ください
ORDER No. (PRODUCT No.) : REFER TO SHEET 6 FOR PRODUCT LIST.

213227 * * * *
 シリーズ番号 (SERIES NO) 極数 (CIRCUIT SIZE) 色 (COLOR) 金めっき厚 (GOLD PLATING THICKNESS)

CIRCUIT	No.	GOLD THK [micro-meter]	No.	COLOR
08 ~ 34	1	0.1	0	ナチュラル NATURAL
	3	0.38	1	黒 BLACK
	7	0.76		

		28.0	24.0	29.8	34
5		26.5	22.5	28.3	32
		25.0	21.0	26.8	30
	4		23.5	19.5	25.3
		22.0	18.0	23.8	26
		20.5	16.5	22.3	24
		19.0	15.0	20.8	22
		17.5	13.5	19.3	20
		16.0	12.0	17.8	18
		14.5	10.5	16.3	16
3		13.0	9.0	14.8	14
		11.5	7.5	13.3	12
		10.0	6.0	11.8	10
	8.5	4.5	10.3	8	
D	C	B	A	極数	CKT NO

番号 NO	部品 PART	材質 MATERIAL	
①	ハウジング HOUSING	ポリアミド(PA) UL94V-0 色 : SEE CHART POLYAMIDE(PA) UL94V-0 COLOR : SEE CHART	
②	ターミナル TERMINAL	銅合金 COPPER ALLOY	
		コンタクト部 CONTACT AREA	金めっき : 製品一覧参照 GOLD PLATING : SEE PRODUCT LIST
		テール部 TAIL AREA	無光沢錫めっき : 1.0 micro-meter MIN MATTE TIN PLATING : 1.0 micro-meter MIN
④	ネイル NAIL	下地めっき(全面) UNDER PLATING (WHOLE SURFACE)	ニッケルめっき : 2.0 micro-meters MIN NICKEL PLATING : 2.0 micro-meters MIN
		黄銅 BRASS	
		無光沢錫めっき : 1.0 micro-meter MIN MATTE TIN PLATING	
		ニッケルめっき(下地) : 1.0 micro-meter MIN NICKEL PLATING (UNDER PLATING)	

THIS DRAWING CONTAINS INFORMATION THAT IS PROPRIETARY TO MOLEX ELECTRONIC TECHNOLOGIES, LLC AND SHOULD NOT BE USED WITHOUT WRITTEN PERMISSION		CURRENT REV DESC:		molex			
DIMENSION UNITS: mm	SCALE: 4:1	EC NO: 627908 DRWN: MIKEDA01 2019/11/22 CHK'D: SAKIYAMA 2019/11/22 APPR: KOMURAKAMI 2019/11/25			CLIK-MATE 1.5 DUAL ROW SMT VT TYPE GOLD PLATING		
GENERAL TOLERANCES (UNLESS SPECIFIED)		INITIAL REVISION:			PRODUCT CUSTOMER DRAWING		
ANGULAR TOL ± 3.0°	4 PLACES ± 0.2	DRWN: MIKEDA01 2019/10/01			DOCUMENT NUMBER		
3 PLACES ± 0.2	2 PLACES ± 0.2	APPR: KOMURAKAMI 2019/11/20			2132270000-SD		
1 PLACE ± 0.2	0 PLACES ± 0.2	DRAWING			DOC TYPE DOC PART REVISION		
DRAFT WHERE APPLICABLE MUST REMAIN WITHIN DIMENSIONS	THIRD ANGLE PROJECTION	A3-SIZE	SERIES: 213227	MATERIAL NUMBER: 213227****	CUSTOMER: GENERAL	SHEET NUMBER: 1 OF 6	

コネクタ外形
CONNECTOR OUTLINE

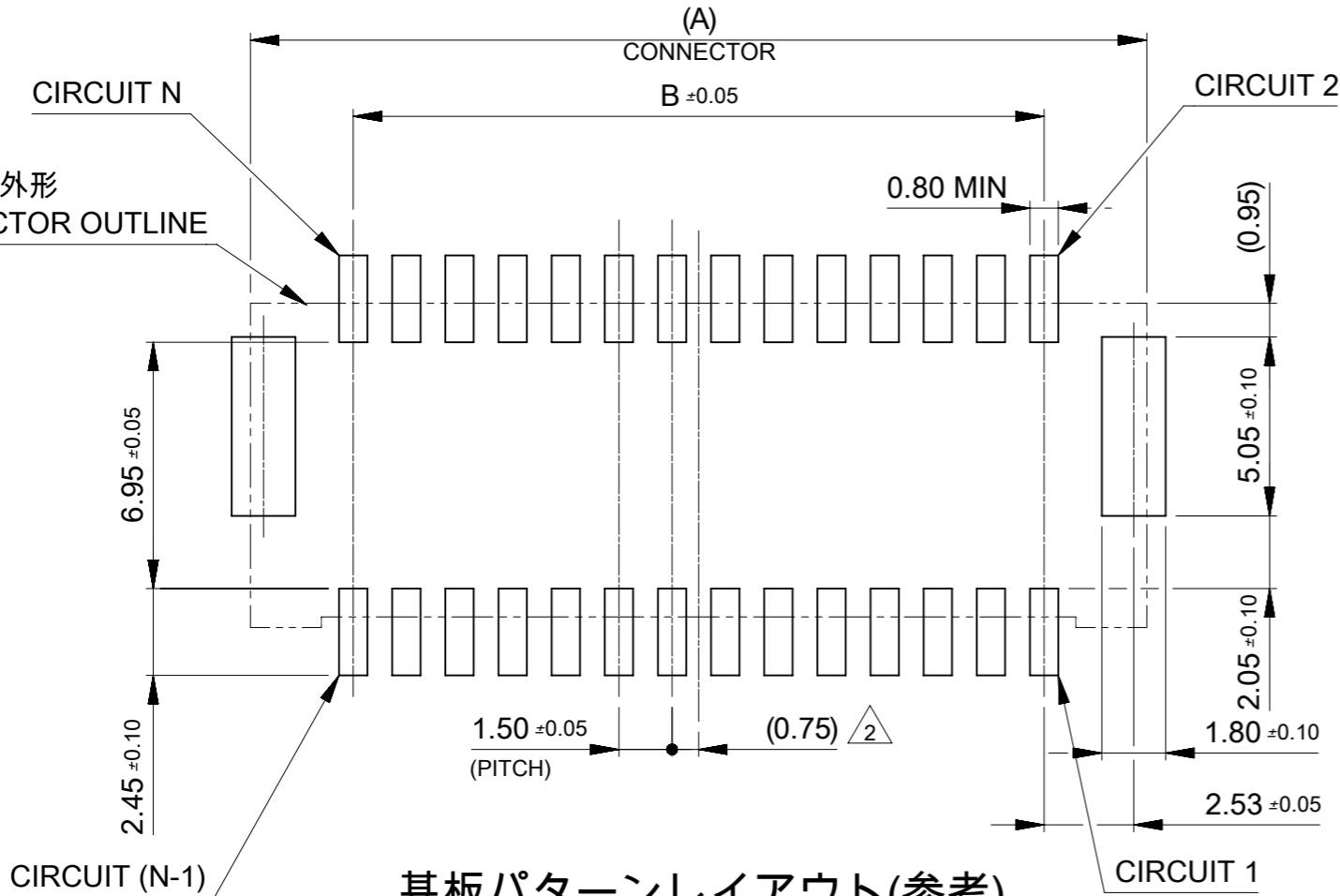

基板パターンレイアウト(参考)
 RECCOMENDED PCB PATTERN LAYOUT (REF.)
 (参考 : メタルマスク厚さ 0.10mm, マスク開口率100%)
 (REFERENCE: METAL MASK THICKNESS 0.10MM, APERTURE RATIO 100%)

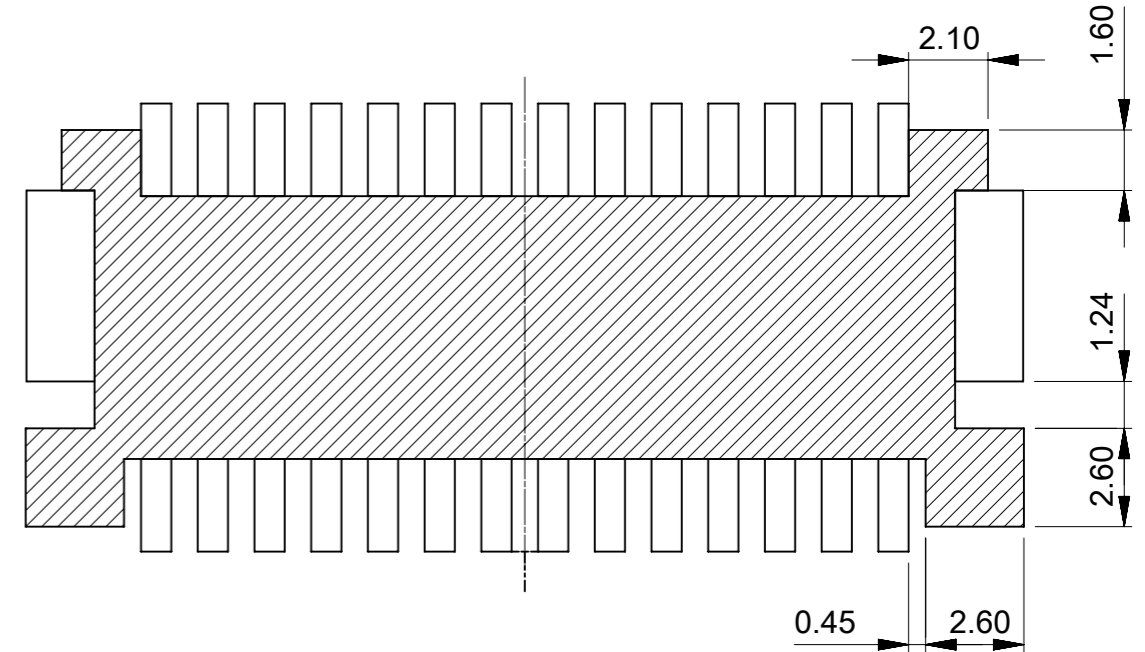

パターン非推奨エリア

パターンを引き回す際は、製品機能に影響がないことをご確認ください。
 PATTERN IS NOT RECCOMENDED ON THE HATCHED AREA.
 PLEASE CHECK NOT TO HAVE PROBLEM FOR PRODUCT FUNCTION
 WHEN SETTING PATTERN ON THE HATCHED AREA.

THIS DRAWING CONTAINS INFORMATION THAT IS PROPRIETARY TO MOLEX ELECTRONIC TECHNOLOGIES, LLC AND SHOULD NOT BE USED WITHOUT WRITTEN PERMISSION											
DIMENSION UNITS	SCALE	CURRENT REV DESC:					molex				
mm	5:1										
GENERAL TOLERANCES (UNLESS SPECIFIED)		EC NO: 627908					CLIK-MATE 1.5				
ANGULAR TOL	± 3.0 °	DRWN: MIKEDA01 2019/11/22					DUAL ROW SMT VT TYPE GOLD PLATING				
4 PLACES	± 0.2	CHK'D: SAKIYAMA 2019/11/22					PRODUCT CUSTOMER DRAWING				
3 PLACES	± 0.2	APPR: KOMURAKAMI 2019/11/25					DOCUMENT NUMBER				
2 PLACES	± 0.2	INITIAL REVISION:					2132270000-SD		DOC TYPE	DOC PART	REVISION
1 PLACE	± 0.2	DRWN: MIKEDA01 2019/10/01					PSD		000	B	
0 PLACES	± 0.2	APPR: KOMURAKAMI 2019/11/20					MATERIAL NUMBER		CUSTOMER		SHEET NUMBER
DRAFT WHERE APPLICABLE MUST REMAIN WITHIN DIMENSIONS		THIRD ANGLE PROJECTION	DRAWING	SERIES	MATERIAL NUMBER	CUSTOMER		SHEET NUMBER			
			A3-SIZE	213227	213227****	GENERAL		2 OF 6			

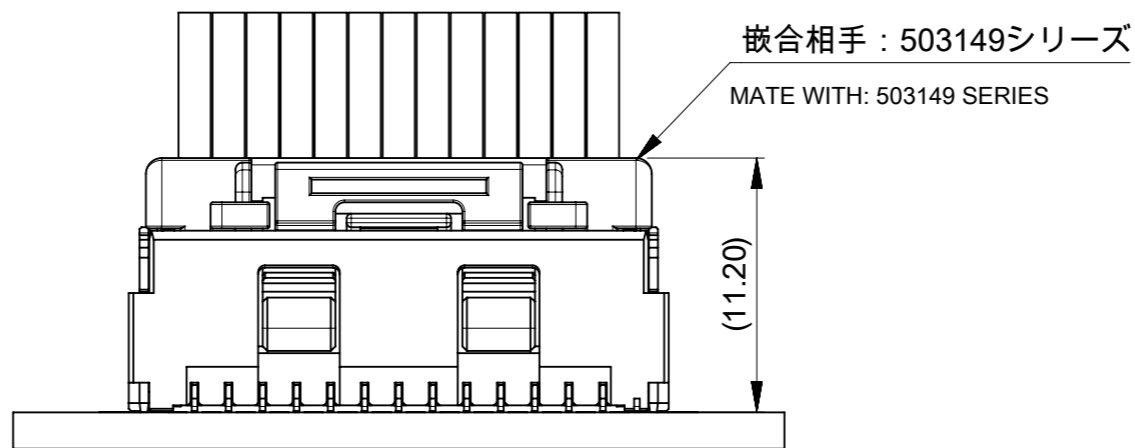
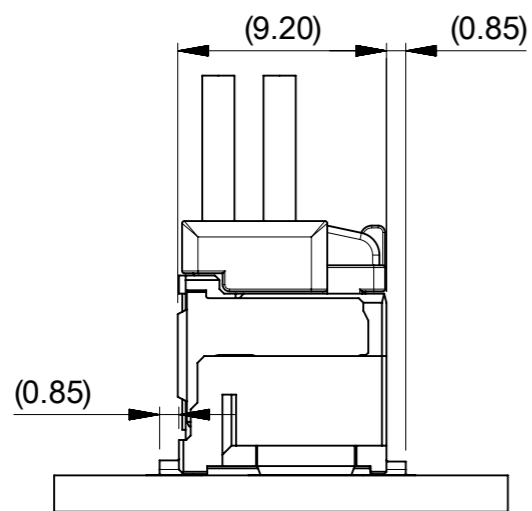

嵌合図
MATED CONNECTORS

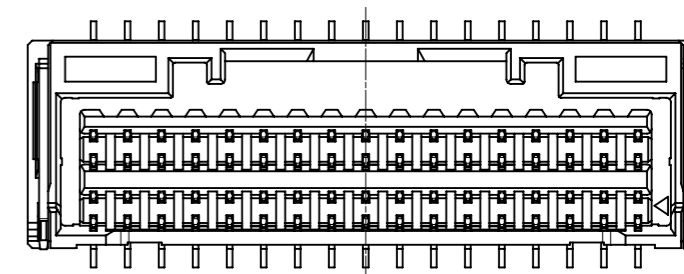
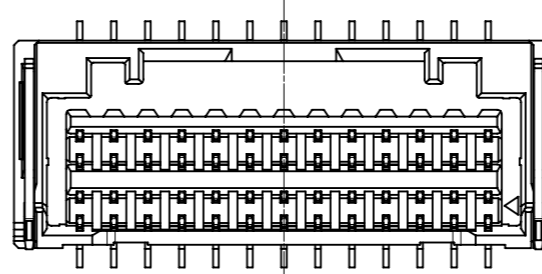
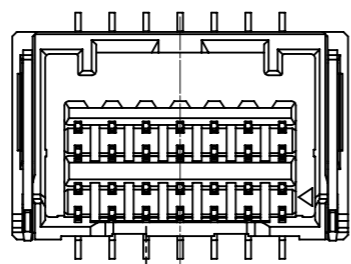
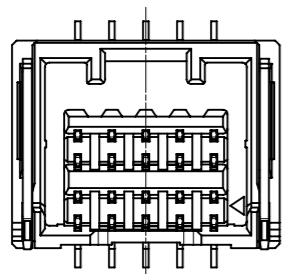
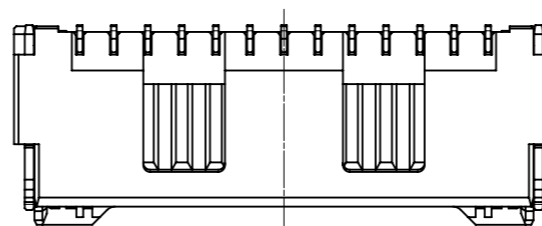
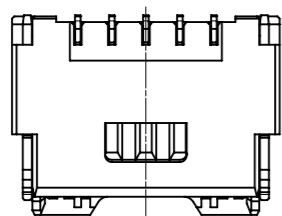

8-10極
8-10 CKT

12-18極
12-18 CKT

20-28極
20-28 CKT

30-34極
30-34 CKT

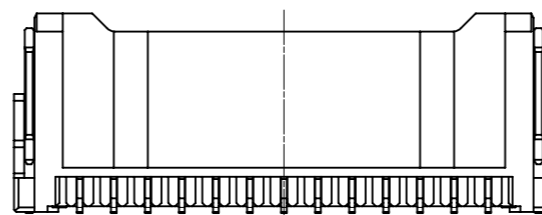
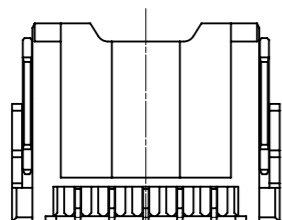

極数別ハウジング形状
HOUSING SHAPE OF EACH CKTS

THIS DRAWING CONTAINS INFORMATION THAT IS PROPRIETARY TO MOLEX ELECTRONIC TECHNOLOGIES, LLC AND SHOULD NOT BE USED WITHOUT WRITTEN PERMISSION		CURRENT REV DESC:		molex		
DIMENSION UNITS	SCALE	EC NO: 627908				
mm	5:1	DRWN: MIKEDA01 2019/11/22		DUAL ROW SMT VT TYPE GOLD PLATING		
GENERAL TOLERANCES (UNLESS SPECIFIED)		CHK'D: SAKIYAMA 2019/11/22		PRODUCT CUSTOMER DRAWING		
ANGULAR TOL	± 3.0°	APPR: KOMURAKAMI 2019/11/25		DOCUMENT NUMBER		
4 PLACES	± 0.2	INITIAL REVISION:		2132270000-SD		
3 PLACES	± 0.2	DRWN: MIKEDA01 2019/10/01		DOC TYPE	DOC PART	REVISION
2 PLACES	± 0.2	APPR: KOMURAKAMI 2019/11/20		PSD	000	B
1 PLACE	± 0.2	DRAFT WHERE APPLICABLE MUST REMAIN WITHIN DIMENSIONS		SHEET NUMBER		
0 PLACES	± 0.2	THIRD ANGLE PROJECTION	DRAWING	SERIES	MATERIAL NUMBER	CUSTOMER
			A3-SIZE	213227	213227****	GENERAL

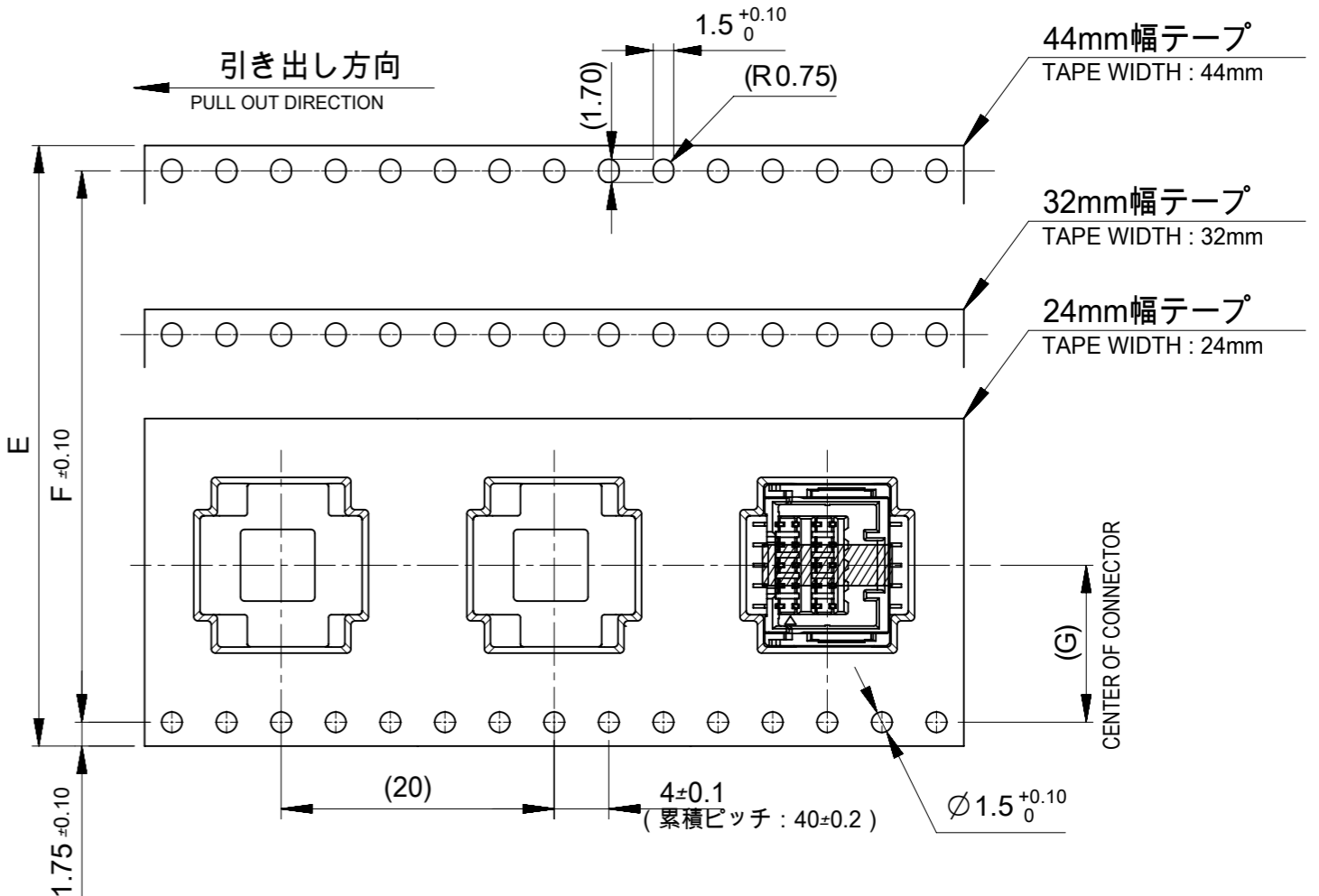
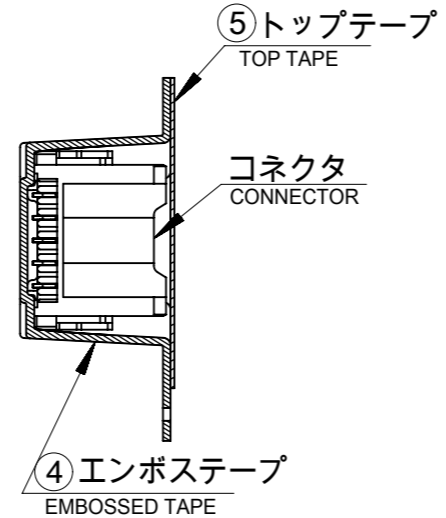
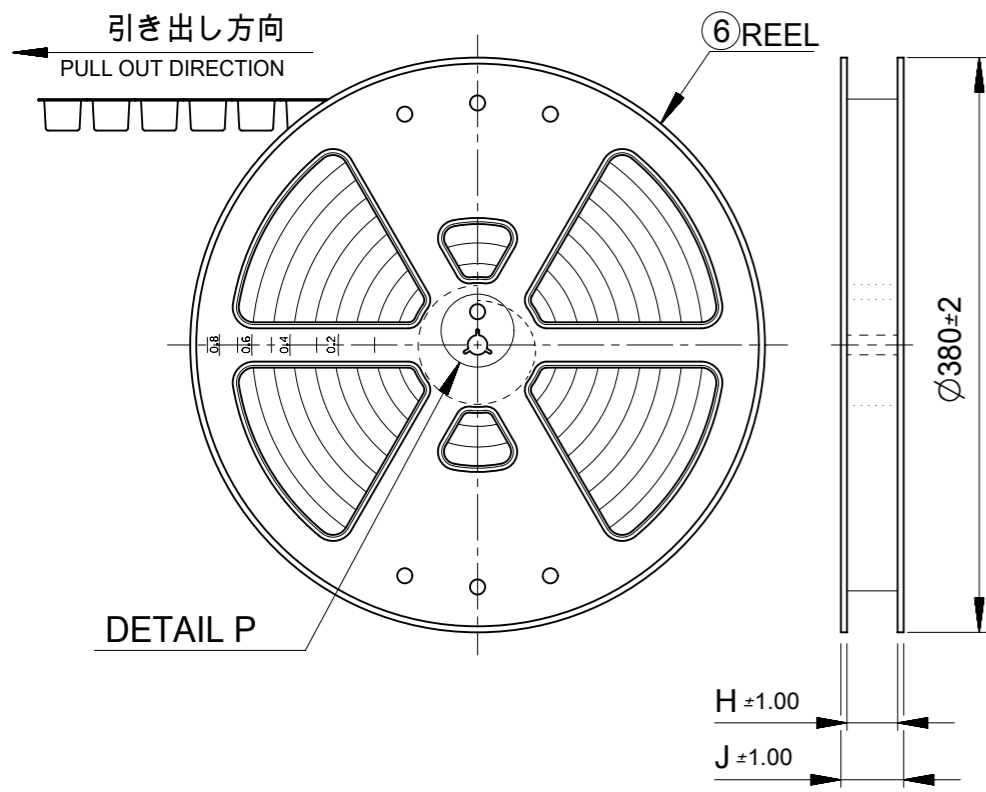

NOTE

- 5. 梱包数量 : 450個 / リール
NUMBER OF CONNECTORS : 450 PIECES/REEL
- 6. リードテープ長さ
LEAD TAPE LENGTH

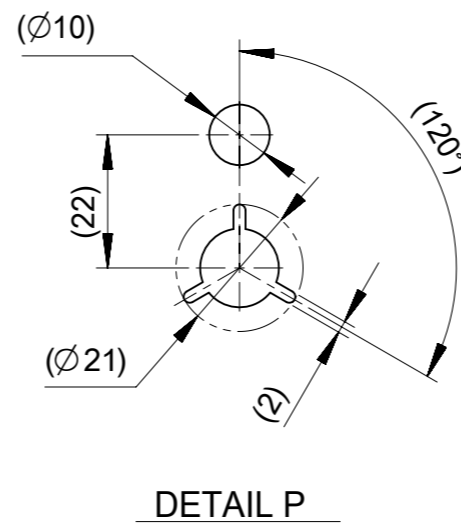
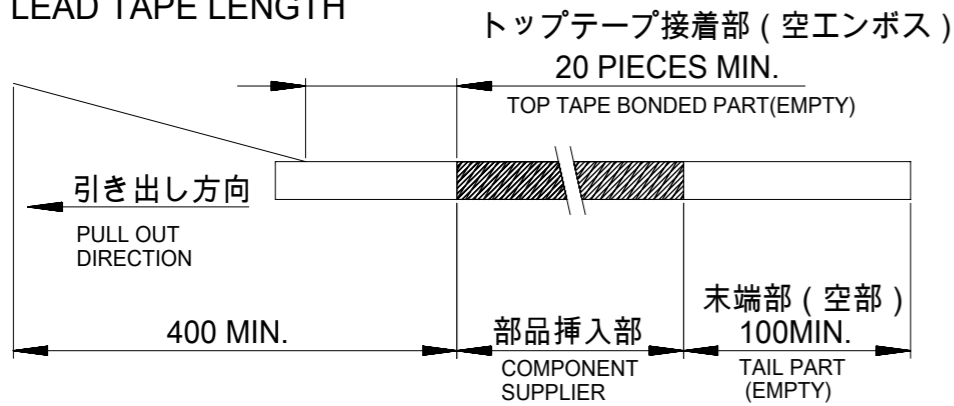

7. トップテープの剥離強度はJIS C0806-3に準拠
TOP TAPE PEELING OFF FORCE IS DIFINED BY JIS C0806-3

					34
					32
					30
					28
					26
					24
					22
					20
					18
					16
					14
					12
					10
					8
J	H	G	F	エンボステープ幅E WIDTH OF TAPE	CKT NO.

THIS DRAWING CONTAINS INFORMATION THAT IS PROPRIETARY TO MOLEX ELECTRONIC TECHNOLOGIES, LLC AND SHOULD NOT BE USED WITHOUT WRITTEN PERMISSION

DIMENSION UNITS: mm SCALE: 1:1

GENERAL TOLERANCES (UNLESS SPECIFIED):
 ANGULAR TOL ± 3.0°
 4 PLACES ± 0.2
 3 PLACES ± 0.2
 2 PLACES ± 0.2
 1 PLACE ± 0.2
 0 PLACES ± 0.2

THIRD ANGLE PROJECTION

DRAWING: A3-SIZE SERIES: 213227 MATERIAL NUMBER: 213227**** CUSTOMER: GENERAL SHEET NUMBER: 4 OF 6

CURRENT REV DESC:
 EC NO: 627908
 DRWN: MIKEDA01 2019/11/22
 CHK'D: SAKIYAMA 2019/11/22
 APPR: KOMURAKAMI 2019/11/25

INITIAL REVISION:
 DRWN: MIKEDA01 2019/10/01
 APPR: KOMURAKAMI 2019/11/20

PRODUCT CUSTOMER DRAWING

DOCUMENT NUMBER: 2132270000-SD DOC TYPE: PSD DOC PART: 000 REVISION: B

molex

CLIK-MATE 1.5
DUAL ROW SMT VT TYPE GOLD PLATING

番号 No.	部品 PART	材質 MATERIAL
④	エンボステープ EMBOSSSED TAPE	ポリスチレン(PS) POLYSTYLENE
⑤	トップテープ TOP TAPE	ポリエチレン、ポリエチレンテレフタレート POLYETHYLENE (PE), POLYETHYLENE TELEPHTHALATE(PET)
⑥	リール REEL	ポリスチレン (リサイクル材を含む) POLYSTYLENE (CONTAINED RECYCLED MATERIAL)

△ 3 適用製品及び各種仕様書
 APPLICABLE PRODUCTS AND VARIOUS SPECIFICATIONS

梱包仕様書 PACKAGING SPECIFICATION	PART NUMBER 213227 ****	DOCUMENT NUMBER 2132279200-SPK
----------------------------------	----------------------------	-----------------------------------

適用嵌合相手 MATE WITH	HOUSING	TERMINAL (GOLD PLATING)		
		PLATING THK	#24-28	#28-30
製品番号 PRODUCT NUMBER	503149 ****	0.1 micro-meters	213028 1*00	213029 1*00
		0.38 micro-meters	213028 3*00	213029 3*00
		0.76 micro-meters	213028 7*00	213029 7*00
製品仕様書 PRODUCT SPECIFICATION	5031490001-PS/PS/000			
アプリケーション仕様書 APPLICATION SPECIFICATION	AS-503149-001 (Japanese ver) 5031490000/PS/000 (English ver)			

THIS DRAWING CONTAINS INFORMATION THAT IS PROPRIETARY TO MOLEX ELECTRONIC TECHNOLOGIES, LLC AND SHOULD NOT BE USED WITHOUT WRITTEN PERMISSION										
DIMENSION UNITS	SCALE	CURRENT REV DESC:				molex				
mm	1:1	EC NO: 627908 DRWN: MIKEDA01 2019/11/22 CHK'D: SAKIYAMA 2019/11/22 APPR: KOMURAKAMI 2019/11/25 INITIAL REVISION: DRWN: MIKEDA01 2019/10/01 APPR: KOMURAKAMI 2019/11/20				CLICK-MATE 1.5 DUAL ROW SMT VT TYPE GOLD PLATING				
GENERAL TOLERANCES (UNLESS SPECIFIED)						PRODUCT CUSTOMER DRAWING				
ANGULAR TOL ± 3.0 °						DOCUMENT NUMBER		DOC TYPE	DOC PART	REVISION
4 PLACES ± 0.2						2132270000-SD		PSD	000	B
3 PLACES ± 0.2						MATERIAL NUMBER		CUSTOMER		SHEET NUMBER
2 PLACES ± 0.2						213227****		GENERAL		5 OF 6
1 PLACE ± 0.2		DRAWING		SERIES						
0 PLACES ± 0.2		A3-SIZE	213227							
DRAFT WHERE APPLICABLE MUST REMAIN WITHIN DIMENSIONS		THIRD ANGLE PROJECTION								

4 製品一覧
PRODUCTS LIST

黒 BLACK	ナチュラル NATURAL	HOUSING COLOR		
213227 3411	213227 3410	34	213227 **1* (GOLD PLATING THICKNESS: 0.1 micro-meters MIN)	
213227 3211	213227 3210	32		
213227 3011	213227 3010	30		
213227 2811	213227 2810	28		
213227 2611	213227 2610	26		
213227 2411	213227 2410	24		
213227 2211	213227 2210	22		
213227 2011	213227 2010	20		
213227 1811	213227 1810	18		
213227 1611	213227 1610	16		
213227 1411	213227 1410	14		
213227 1211	213227 1210	12		
213227 1011	213227 1010	10		
213227 0811	213227 0810	8		
オーダー番号 ORDER No		極数 CKT		MODEL NO

黒 BLACK	ナチュラル NATURAL	HOUSING COLOR		
213227 3431	213227 3430	34	213227 **3* (GOLD PLATING THICKNESS: 0.38 micro-meters MIN)	
213227 3231	213227 3230	32		
213227 3031	213227 3030	30		
213227 2831	213227 2830	28		
213227 2631	213227 2630	26		
213227 2431	213227 2430	24		
213227 2231	213227 2230	22		
213227 2031	213227 2030	20		
213227 1831	213227 1830	18		
213227 1631	213227 1630	16		
213227 1431	213227 1430	14		
213227 1231	213227 1230	12		
213227 1031	213227 1030	10		
213227 0831	213227 0830	8		
オーダー番号 ORDER No		極数 CKT		MODEL NO

黒 BLACK	ナチュラル NATURAL	HOUSING COLOR		
213227 3471	213227 3470	34	213227 **7* (GOLD PLATING THICKNESS: 0.76 micro-meters MIN.)	
213227 3271	213227 3270	32		
213227 3071	213227 3070	30		
213227 2871	213227 2870	28		
213227 2671	213227 2670	26		
213227 2471	213227 2470	24		
213227 2271	213227 2270	22		
213227 2071	213227 2070	20		
213227 1871	213227 1870	18		
213227 1671	213227 1670	16		
213227 1471	213227 1470	14		
213227 1271	213227 1270	12		
213227 1071	213227 1070	10		
213227 0871	213227 0870	8		
オーダー番号 ORDER No		極数 CKT		MODEL NO

THIS DRAWING CONTAINS INFORMATION THAT IS PROPRIETARY TO MOLEX ELECTRONIC TECHNOLOGIES, LLC AND SHOULD NOT BE USED WITHOUT WRITTEN PERMISSION													
DIMENSION UNITS		SCALE		CURRENT REV DESC:				molex					
mm		1:1											
GENERAL TOLERANCES (UNLESS SPECIFIED)				EC NO: 627908 DRWN: MIKEDA01 2019/11/22 CHK'D: SAKIYAMA 2019/11/22 APPR: KOMURAKAMI 2019/11/25 INITIAL REVISION: DRWN: MIKEDA01 2019/10/01 APPR: KOMURAKAMI 2019/11/20				CLIK-MATE 1.5 DUAL ROW SMT VT TYPE GOLD PLATING					
ANGULAR TOL ± 3.0 °								PRODUCT CUSTOMER DRAWING					
4 PLACES ± 0.2								DOCUMENT NUMBER		DOC TYPE		DOC PART	
3 PLACES ± 0.2								2132270000-SD		PSD		000	
2 PLACES ± 0.2								SERIES		CUSTOMER		REVISION	
1 PLACE ± 0.2								213227		GENERAL		B	
0 PLACES ± 0.2				MATERIAL NUMBER		SHEET NUMBER							
DRAFT WHERE APPLICABLE MUST REMAIN WITHIN DIMENSIONS				THIRD ANGLE PROJECTION		DRAWING		SHEET NUMBER					
				A3-SIZE		6 OF 6							