

**NOTE**

- 端子テール部およびネイルの平坦度: 0.1mm MAX  
TAIL AND NAIL COPLANARITY TO BE 0.1mm MAX
- (極数/2) = 偶数 に適用  
APPLY FOR (CIRCUIT SIZE/2) = EVEN
- △ 関連製品・書類はSHEET 5を参照ください  
REFER TO SHEET 5 ABOUT RELATED PRODUCTS AND DOCUMENTS

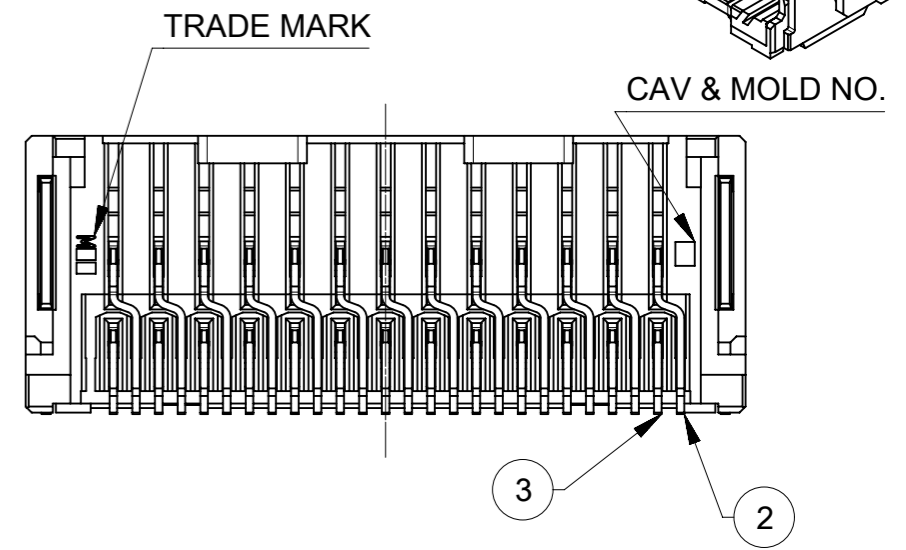
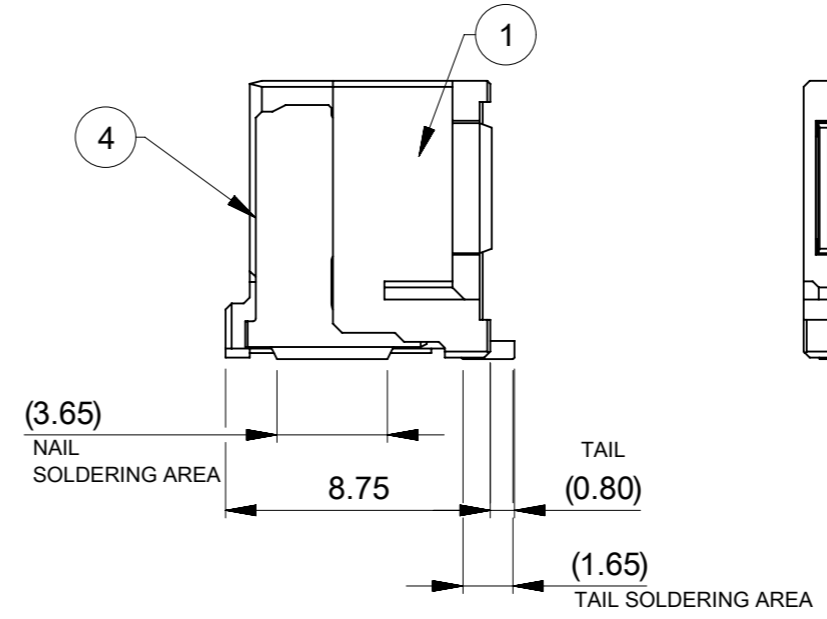
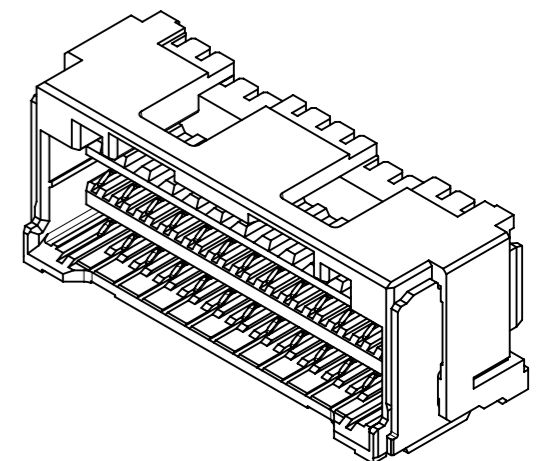

△ 4. オーダー番号(製品番号): SHEET 6の製品一覧を参照のこと  
ORDER No. (PRODUCT No.) : REFER TO SHEET 6 FOR PRODUCT LIST.

**213228** \* \* \* \*

↑ シリーズ番号 SERIES NO  
↑ 極数 CIRCUIT SIZE  
↑ 色 COLOR  
↑ 金めっき厚 GOLD PLATING THICKNESS

22.0	±0.25	18.0	23.8	26
20.5		16.5	22.3	24
19.0		15.0	20.8	22
17.5		13.5	19.3	20
16.0		12.0	17.8	18
14.5		10.5	16.3	16
13.0		9.0	14.8	14
11.5	7.5	13.3	12	
10.0	6.0	11.8	10	
8.5	±0.2	4.5	10.3	8
C		B	A	極数 CKT.NO.

番号 NO.	部品 PART	材質 MATERIAL	
①	ハウジング HOUSING	ポリアミド(PA) UL94V-0 色 : SEE CHART POLYAMIDE(PA) UL94V-0 COLOR : SEE CHART	
② ③	ターミナル TERMINAL	銅合金 COPPER ALLOY	
		コンタクト部 CONTACT AREA	金めっき : 製品一覧参照 GOLD PLATING : SEE PRODUCT LIST
		テール部 TAIL AREA	無光沢錫めっき : 1.0 micro-meter MIN MATTE TIN PLATING: 1.0 micro-meter MIN
④	ネイル NAIL	下地めっき(全面) UNDER PLATING (WHOLE SURFACE)	ニッケルめっき : 2.0 micro-meters MIN NICKEL PLATING : 2.0 micro-meters MIN
		黄銅 BRASS	無光沢錫めっき : 1.0 micro-meter MIN MATTE TIN PLATING
		ニッケルめっき(下地) : 1.0 micro-meter MIN NICKEL PLATING(UNDER PLATING)	

CIRCUIT	No.	GOLD THK[μm]	No.	COLOR
08 ~ 26	1	0.1	0	ナチュラル NATURAL
	3	0.38	1	黒 BLACK
	7	0.76		

THIS DRAWING CONTAINS INFORMATION THAT IS PROPRIETARY TO MOLEX ELECTRONIC TECHNOLOGIES, LLC AND SHOULD NOT BE USED WITHOUT WRITTEN PERMISSION

DIMENSION UNITS: mm SCALE: 4:1

GENERAL TOLERANCES (UNLESS SPECIFIED):  
ANGULAR TOL ± 3.0°  
4 PLACES ± 0.2  
3 PLACES ± 0.2  
2 PLACES ± 0.2  
1 PLACE ± 0.2  
0 PLACES ± 0.2

DRAFT WHERE APPLICABLE MUST REMAIN WITHIN DIMENSIONS

THIRD ANGLE PROJECTION

DRAWING: A3-SIZE

SERIES: 213228

MATERIAL NUMBER: 213228\*\*\*\*

CUSTOMER: 1 OF 6

CURRENT REV DESC:  
EC NO: 627908  
DRWN: MIKEDA01 2019/11/22  
CHK'D: SAKIYAMA 2019/11/22  
APPR: KOMURAKAMI 2019/11/25

INITIAL REVISION:  
DRWN: MIKEDA01 2019/10/01  
APPR: KOMURAKAMI 2019/11/20

DOCUMENT NUMBER: 2132280000-SD

DOC TYPE: PSD

DOC PART: 000

REVISION: B

**molex**

CLIK-MATE 1.5  
DUAL ROW SMT R/A TYPE GOLD PLATING

PRODUCT CUSTOMER DRAWING

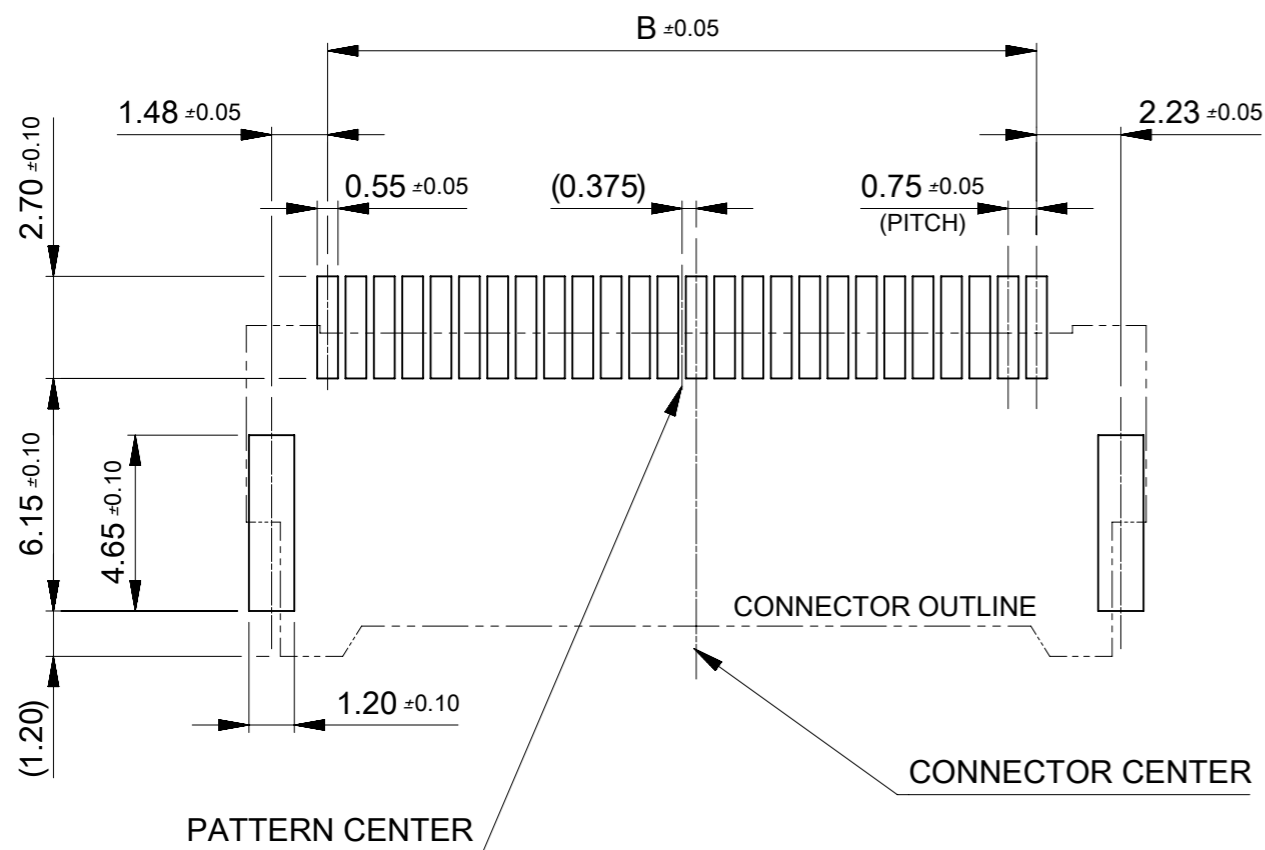

**基板パターンレイアウト(参考)**  
RECCOMENDED PCB PATTERN LAYOUT (REF)

(参考 : メタルマスク厚さ 0.10mm, マスク開口率100%)  
(REFERENCE: METAL MASK THICKNESS 0.10MM, APERTURE RATIO 100%)

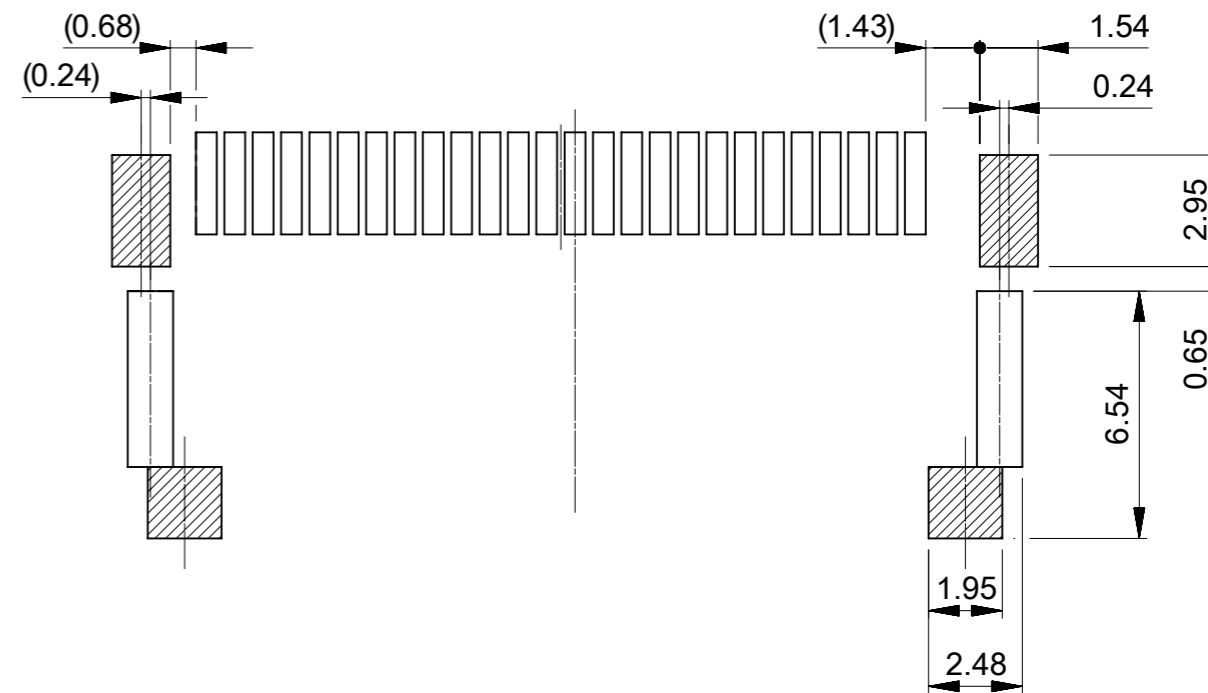

**パターン非推奨エリア**

パターンを引き回す際は、製品機能に影響がないことをご確認ください。  
PATTERN IS NOT RECCOMENDED ON THE HATCHED AREA.  
PLEASE CHECK NOT TO HAVE PROBLEM FOR PRODUCT FUNCTION  
WHEN SETTING PATTERN ON THE HATCHED AREA.

THIS DRAWING CONTAINS INFORMATION THAT IS PROPRIETARY TO MOLEX ELECTRONIC TECHNOLOGIES, LLC AND SHOULD NOT BE USED WITHOUT WRITTEN PERMISSION									
DIMENSION UNITS		SCALE		CURRENT REV DESC:				<b>molex</b>	
mm		5:1							
GENERAL TOLERANCES (UNLESS SPECIFIED)				EC NO: 627908				CLIK-MATE 1.5	
ANGULAR TOL ± 3.0 °				DRWN: MIKEDA01 2019/11/22				DUAL ROW SMT R/A TYPE GOLD PLATING	
4 PLACES ± 0.2				CHK'D: SAKIYAMA 2019/11/22				PRODUCT CUSTOMER DRAWING	
3 PLACES ± 0.2				APPR: KOMURAKAMI 2019/11/25					
2 PLACES ± 0.2				INITIAL REVISION:				DOCUMENT NUMBER	
1 PLACE ± 0.2				DRWN: MIKEDA01 2019/10/01				2132280000-SD	
0 PLACES ± 0.2				APPR: KOMURAKAMI 2019/11/20				PSD 000 B	
DRAFT WHERE APPLICABLE MUST REMAIN WITHIN DIMENSIONS		THIRD ANGLE PROJECTION		DRAWING		SERIES		MATERIAL NUMBER	
				A3-SIZE		213228		213228****	
CUSTOMER		SHEET NUMBER		DATE		TIME			
		2 OF 6		2019/11/25		01:51:46			

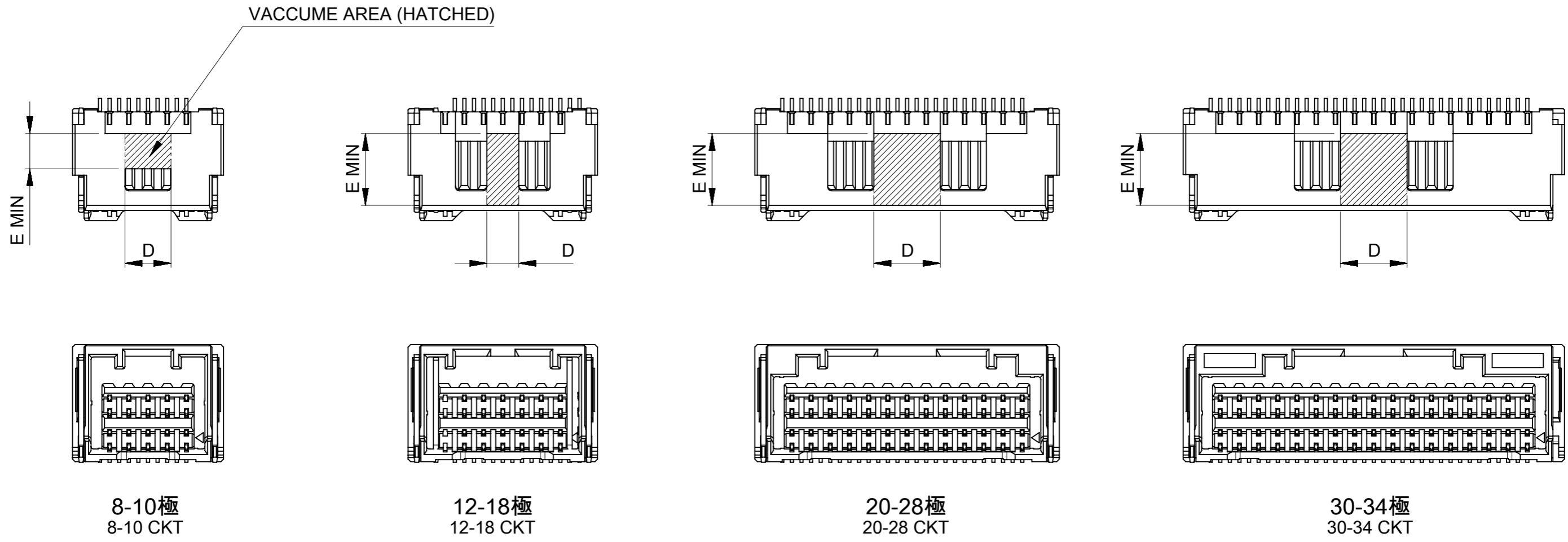

極数別ハウジング形状および吸着エリア  
HOUSING SHAPE AND VACCUME AREA AT EACH CKTS

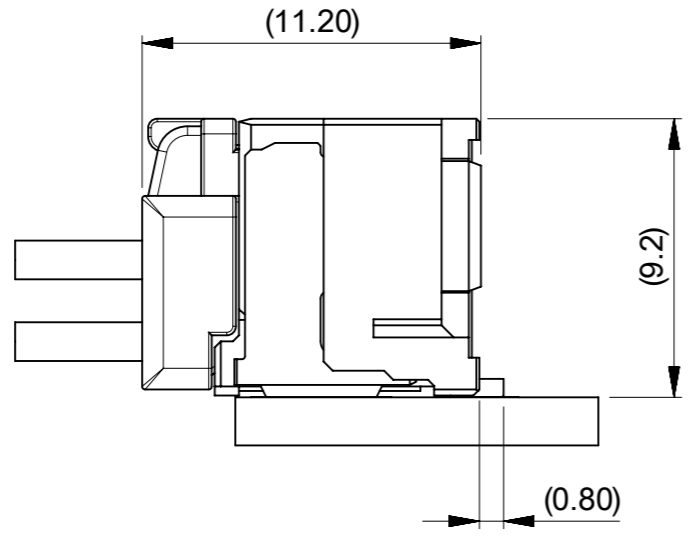

嵌合図  
MATED CONNECTORS

5.6	5.2	26
		24
3.2	3.2	22
		20
		18
2.5	2.5	16
		14
2.3	2.3	12
		10
2.75	3.6	8
E	D	CKT NO

THIS DRAWING CONTAINS INFORMATION THAT IS PROPRIETARY TO MOLEX ELECTRONIC TECHNOLOGIES, LLC AND SHOULD NOT BE USED WITHOUT WRITTEN PERMISSION

DIMENSION UNITS <b>mm</b>	SCALE <b>3:1</b>	CURRENT REV DESC:		<b>molex</b>		
GENERAL TOLERANCES (UNLESS SPECIFIED)		EC NO: 627908				
ANGULAR TOL ± 3.0 °	4 PLACES ± 0.2	DRWN: MIKEDA01	2019/11/22	PRODUCT CUSTOMER DRAWING		
3 PLACES ± 0.2	2 PLACES ± 0.2	CHK'D: SAKIYAMA	2019/11/22	DOCUMENT NUMBER		
1 PLACE ± 0.2	0 PLACES ± 0.2	APPR: KOMURAKAMI	2019/11/25	2132280000-SD		
DRAFT WHERE APPLICABLE MUST REMAIN WITHIN DIMENSIONS		INITIAL REVISION:		DOC TYPE	DOC PART	REVISION
THIRD ANGLE PROJECTION		DRWING	SERIES	PSD	000	B
A3-SIZE		213228	MATERIAL NUMBER	CUSTOMER		SHEET NUMBER
			213228****			3 OF 6

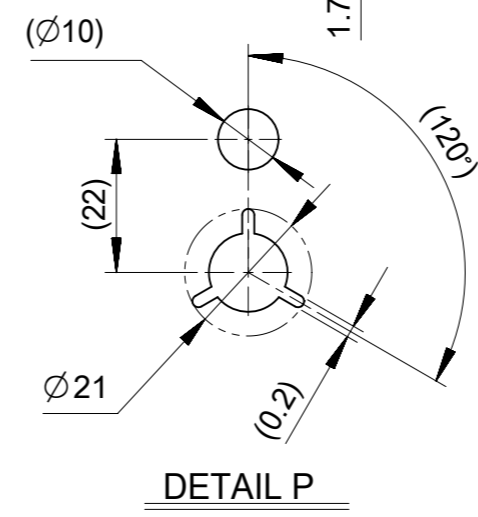
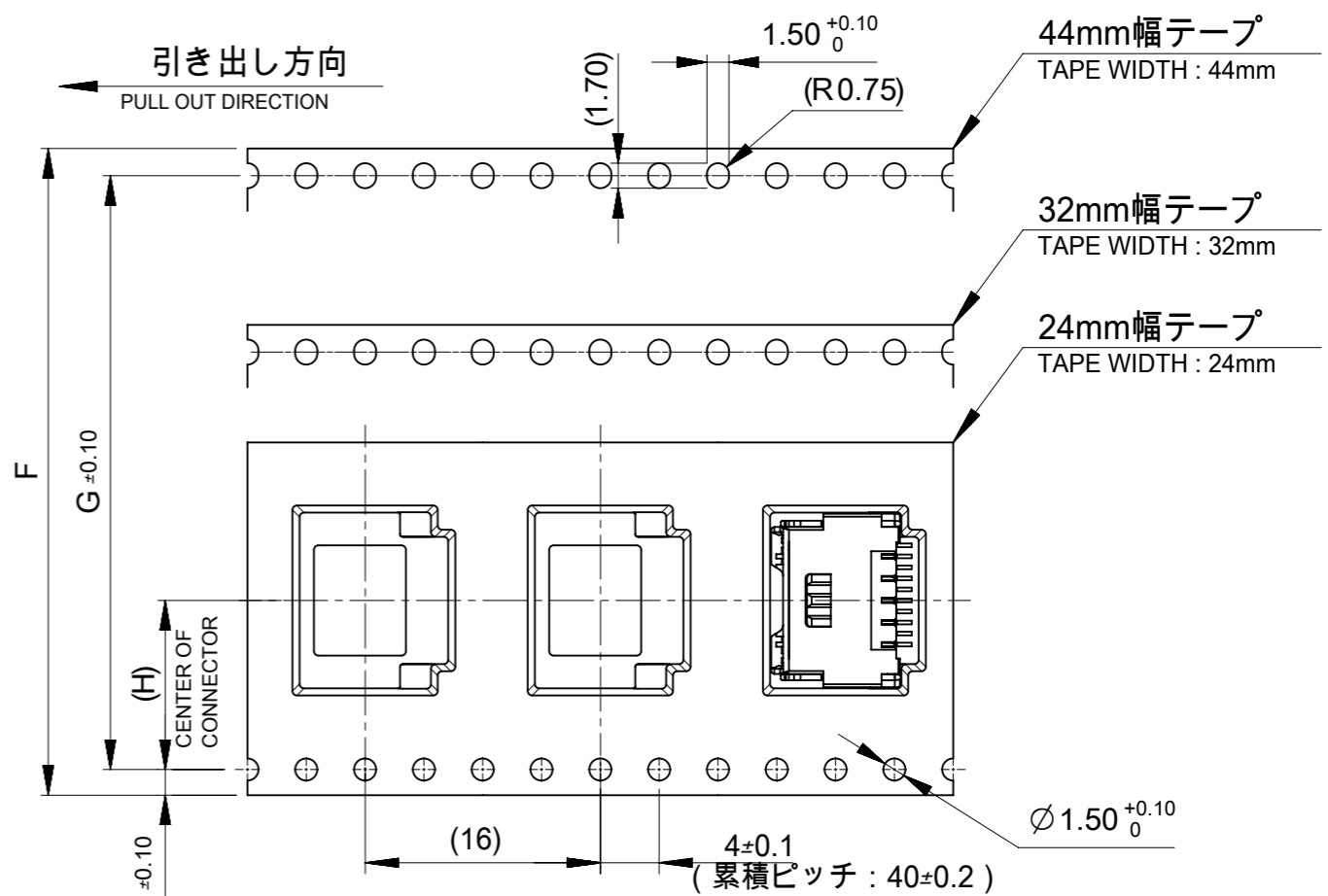
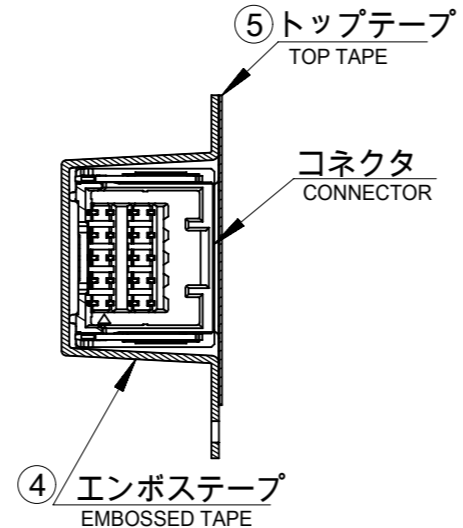
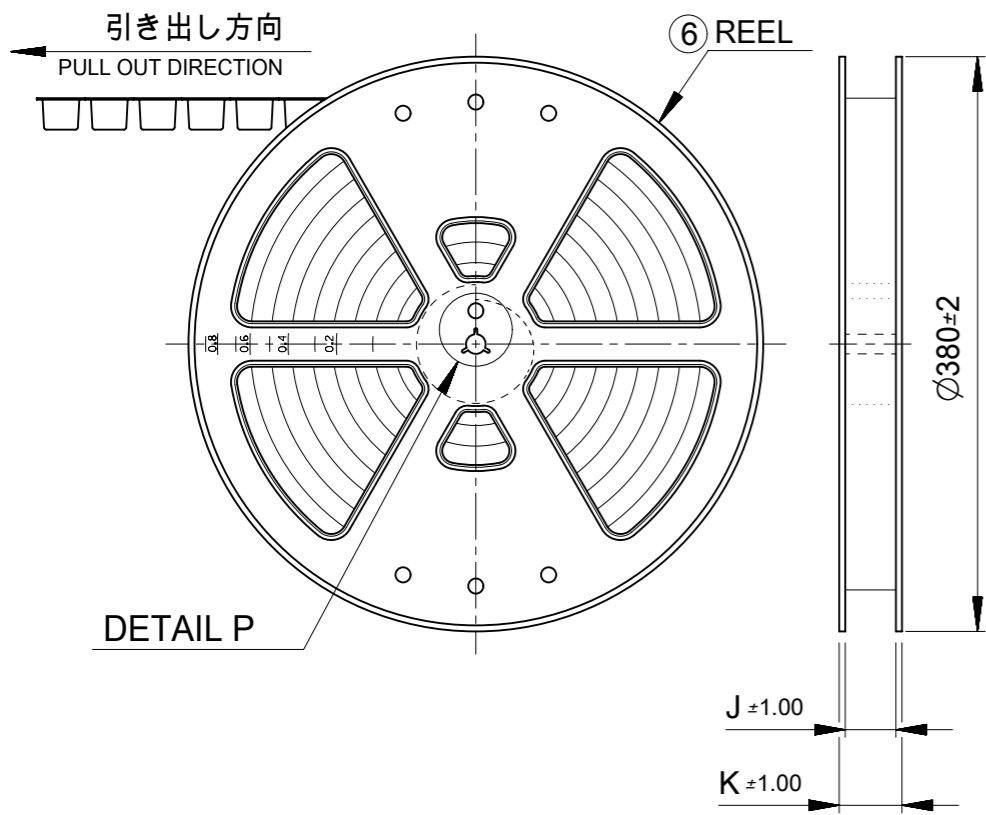

**NOTE**  
 5. 梱包数量 : 550個 / リール  
 NUMBER OF CONNECTORS : 550 PIECES/REEL  
 6. リードテープ長さ  
 LEAD TAPE LENGTH

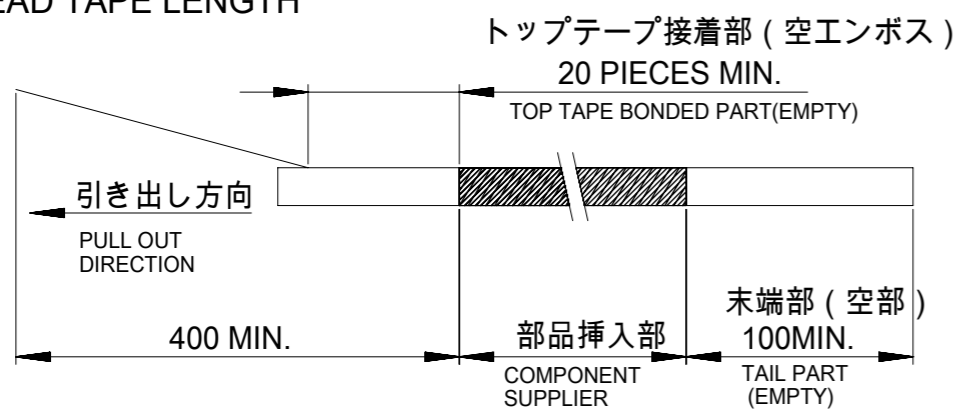

7. トップテープの剥離強度はJIS C0806-3 準拠  
 TOP TAPE PEELING OFF FORCE IS DEFINED BY JIS C0806-3.

49.4	45.4	20.2	40.4	44±0.3	26
					24
					22
					20
					18
					16
					14
					12
					10
					8
K	J	H	G	エンボステープ幅F WIDTH OF TAPE	CKT NO.

番号 No.	部品 PART	材質 MATERIAL
④	エンボステープ EMBOSSSED TAPE	ポリスチレン(PS) POLYSTYLENE
⑤	トップテープ TOP TAPE	ポリエチレン、ポリエチレンテレフタレート POLYETHYLENE (PE), POLYETHYLENE TELEPHTHALATE (PET)
⑥	リール REEL	ポリスチレン (リサイクル材を含む) POLYSTYLENE (CONTAINED RECYCLED MATERIAL)

THIS DRAWING CONTAINS INFORMATION THAT IS PROPRIETARY TO MOLEX ELECTRONIC TECHNOLOGIES, LLC AND SHOULD NOT BE USED WITHOUT WRITTEN PERMISSION

DIMENSION UNITS: mm SCALE: 1:1

CURRENT REV DESC:

**molex**

CLIK-MATE 1.5  
DUAL ROW SMT R/A TYPE GOLD PLATING

PRODUCT CUSTOMER DRAWING

DOCUMENT NUMBER: 2132280000-SD DOC TYPE: PSD DOC PART: 000 REVISION: B

DRAFT WHERE APPLICABLE MUST REMAIN WITHIN DIMENSIONS

THIRD ANGLE PROJECTION

DRAWING: A3-SIZE SERIES: 213228 MATERIAL NUMBER: 213228\*\*\*\* CUSTOMER: SHEET NUMBER: 4 OF 6

△<sub>3</sub> 適用製品及び各種仕様書  
 APPLICABLE PRODUCTS AND VARIOUS SPECIFICATIONS

梱包仕様書 PACKAGING SPECIFICATION	PART NUMBER 213228 ****	DOCUMENT NUMBER 2132289200-SPK
----------------------------------	----------------------------	-----------------------------------

適用嵌合相手 MATE WITH	HOUSING	TERMINAL (GOLD PLATING)		
		PLATING THK	#24-28	#28-30
製品番号 PRODUCT NUMBER	503149 ****	0.1 micro-meters	213028 1*00	213029 1*00
		0.38 micro-meters	213028 3*00	213029 3*00
		0.76 micro-meters	213028 7*00	213029 7*00
製品仕様書 PRODUCT SPECIFICATION	5031490001-PS/PS/000			
アプリケーション仕様書 APPLICATION SPECIFICATION	AS-503149-001 (Japanese ver) 5031490000/PS/000 (English ver)			

THIS DRAWING CONTAINS INFORMATION THAT IS PROPRIETARY TO MOLEX ELECTRONIC TECHNOLOGIES, LLC AND SHOULD NOT BE USED WITHOUT WRITTEN PERMISSION										
DIMENSION UNITS	SCALE	CURRENT REV DESC:				molex				
mm	1:1					CLIK-MATE 1.5 DUAL ROW SMT R/A TYPE GOLD PLATING				
GENERAL TOLERANCES (UNLESS SPECIFIED)		EC NO: 627908				PRODUCT CUSTOMER DRAWING				
ANGULAR TOL ± 3.0 °		DRWN: MIKEDA01      2019/11/22				DOCUMENT NUMBER      DOC TYPE      DOC PART      REVISION				
4 PLACES ± 0.2		CHK'D: SAKIYAMA      2019/11/22				2132280000-SD      PSD      000      B				
3 PLACES ± 0.2		APPR: KOMURAKAMI      2019/11/25								
2 PLACES ± 0.2		INITIAL REVISION:								
1 PLACE ± 0.2		DRWN: MIKEDA01      2019/10/01								
0 PLACES ± 0.2		APPR: KOMURAKAMI      2019/11/20								
DRAFT WHERE APPLICABLE MUST REMAIN WITHIN DIMENSIONS		THIRD ANGLE PROJECTION 	DRAWING A3-SIZE	SERIES 213228	MATERIAL NUMBER 213228****	CUSTOMER	SHEET NUMBER 5 OF 6			

4 製品一覧  
PRODUCTS LIST

黒 BLACK	ナチュラル NATURAL	HOUSING COLOR		
213228 2611	213228 2610	26	213228 **1* (GOLD PLATING THICKNESS: 0.1 micro-meters MIN)	
213228 2411	213228 2410	24		
213228 2211	213228 2210	22		
213228 2011	213228 2010	20		
213228 1811	213228 1810	18		
213228 1611	213228 1610	16		
213228 1411	213228 1410	14		
213228 1211	213228 1210	12		
213228 1011	213228 1010	10		
213228 0811	213228 0810	8		
オーダー番号 ORDER No		極数 CKT		MODEL NO

黒 BLACK	ナチュラル NATURAL	HOUSING COLOR		
213228 2631	213228 2630	26	213228 **3* (GOLD PLATING THICKNESS: 0.38 micro-meters MIN)	
213228 2431	213228 2430	24		
213228 2231	213228 2230	22		
213228 2031	213228 2030	20		
213228 1831	213228 1830	18		
213228 1631	213228 1630	16		
213228 1431	213228 1430	14		
213228 1231	213228 1230	12		
213228 1031	213228 1030	10		
213228 0831	213228 0830	8		
オーダー番号 ORDER No		極数 CKT		MODEL NO

黒 BLACK	ナチュラル NATURAL	HOUSING COLOR		
213228 2671	213228 2670	26	213228 **7* (GOLD PLATING THICKNESS: 0.76 micro-meters MIN)	
213228 2471	213228 2470	24		
213228 2271	213228 2270	22		
213228 2071	213228 2070	20		
213228 1871	213228 1870	18		
213228 1671	213228 1670	16		
213228 1471	213228 1470	14		
213228 1271	213228 1270	12		
213228 1071	213228 1070	10		
213228 0871	213228 0870	8		
オーダー番号 ORDER No		極数 CKT		MODEL NO

THIS DRAWING CONTAINS INFORMATION THAT IS PROPRIETARY TO MOLEX ELECTRONIC TECHNOLOGIES, LLC AND SHOULD NOT BE USED WITHOUT WRITTEN PERMISSION									
DIMENSION UNITS	SCALE	CURRENT REV DESC:				<b>molex</b>			
mm	1:1								
GENERAL TOLERANCES (UNLESS SPECIFIED)		EC NO: 627908				CLIK-MATE 1.5			
ANGULAR TOL	± 3.0 °	DRWN: MIKEDA01 2019/11/22				DUAL ROW SMT R/A TYPE GOLD PLATING			
4 PLACES	± 0.2	CHK'D: SAKIYAMA 2019/11/22				PRODUCT CUSTOMER DRAWING			
3 PLACES	± 0.2	APPR: KOMURAKAMI 2019/11/25				DOCUMENT NUMBER			
2 PLACES	± 0.2	INITIAL REVISION:				2132280000-SD			
1 PLACE	± 0.2	DRWN: MIKEDA01 2019/10/01				DOC TYPE			
0 PLACES	± 0.2	APPR: KOMURAKAMI 2019/11/20				PSD			
DRAFT WHERE APPLICABLE MUST REMAIN WITHIN DIMENSIONS		THIRD ANGLE PROJECTION	DRAWING	SERIES	MATERIAL NUMBER	CUSTOMER	REVISION		
			A3-SIZE	213228			000	B	6 OF 6