

Description

- ◆ Viewing angle:120 deg
- ◆ The materials of the LED dice is GaN
- ◆ 3.45mm×3.45mm×1.95mm
- ◆ RoHS compliant lead-free soldering compatible

RF-XC35-A SERIES

Package Outline

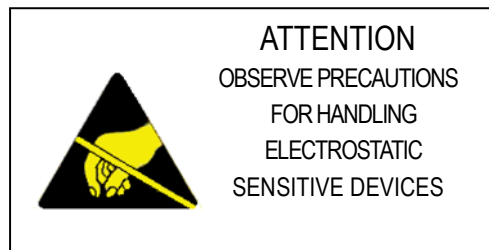
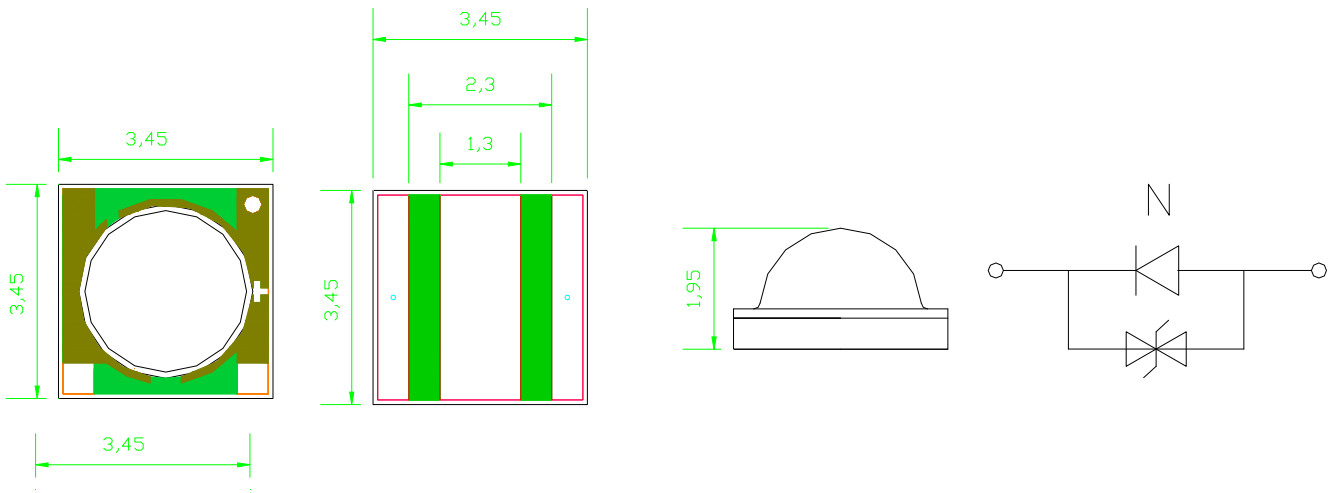

NOTES:

1. All dimensions are in millimeters (inches);
2. Tolerances are ± 0.2 mm unless otherwise noted.

Absolute maximum ratings at Ta=25°C

| Parameter | Symbol | Value | Unit |
|-----------------------------|---------------|----------|------|
| Forward DC current | If | 350 | mA |
| Reverse DC voltage | Vr | 5 | V |
| Operating temperature range | Top | -40~+100 | °C |
| Storage temperature range | Tstg | -40~+100 | °C |
| Peak pulsing current | Ifp | 500 | mA |
| ESD Classification | ESD | 6000 | V |
| Thermal resistance@350mA | θ_{th} | 15 | °C/W |

Electro-optical characteristics at Ta=25°C

| Parameter | Test Condition | Symbol | Value | | | Unit |
|------------------------------|----------------|--------|-------|------|-------|---------|
| | | | Min. | Typ. | Max. | |
| Forward voltage | If=350mA | Vf | 2.8 | -- | 3.8 | V |
| Luminous flux | If=350mA | Φ | 70 | -- | 120 | lm |
| Reverse current | Vr=5V | Ir | -- | -- | 10 | μ A |
| Color Render Index | If=350mA | CRI | 70 | -- | 90 | -- |
| Correlated Color Temperature | If=350mA | CCT | 2800 | -- | 10000 | K |

NOTE: (Tolerance: $\Phi \pm 10\%$, X/Y ± 0.01 , Vf $\pm 0.1V$)

IFP Conditions : Pulse Width ≤ 10 msec. and Duty $\leq 1/10$.

Detail Information

IM BIN Structure

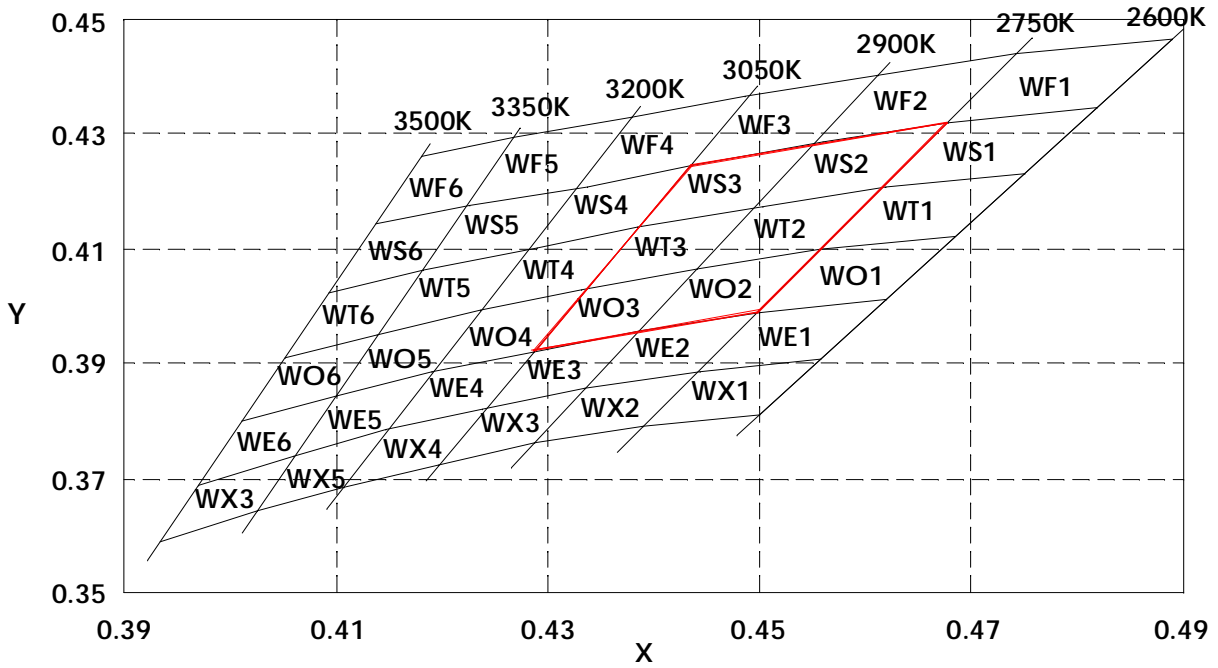

WN BIN Structure

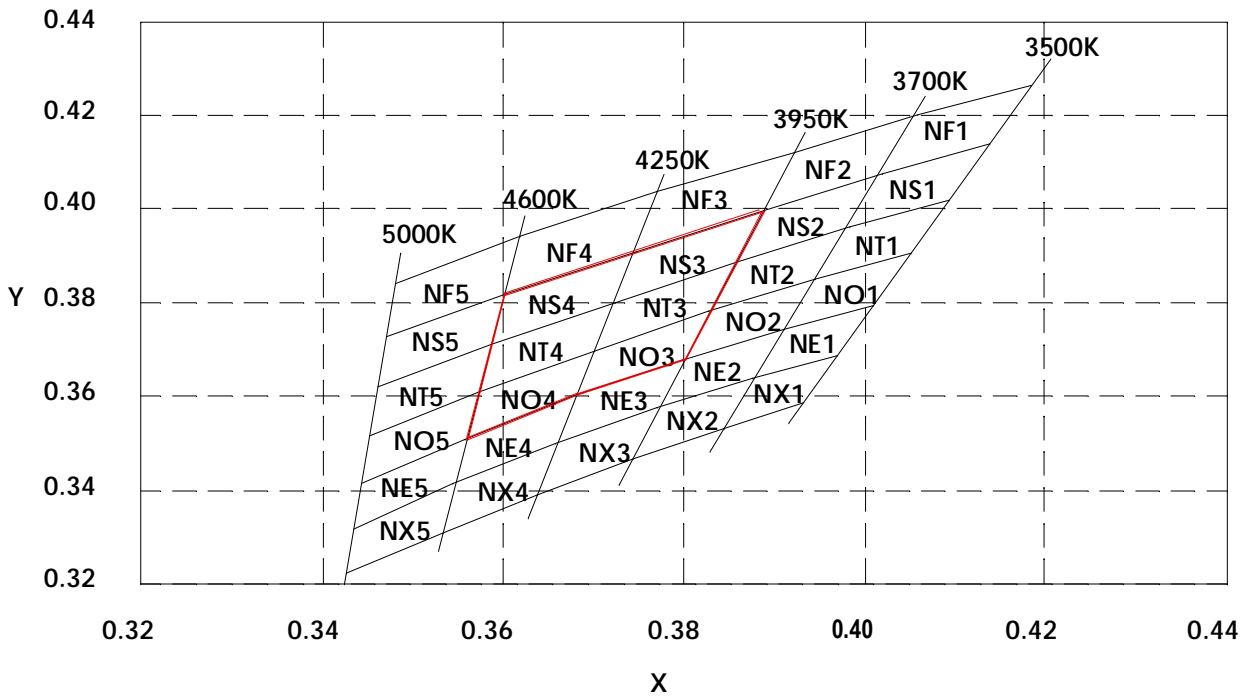

WM BIN Structure

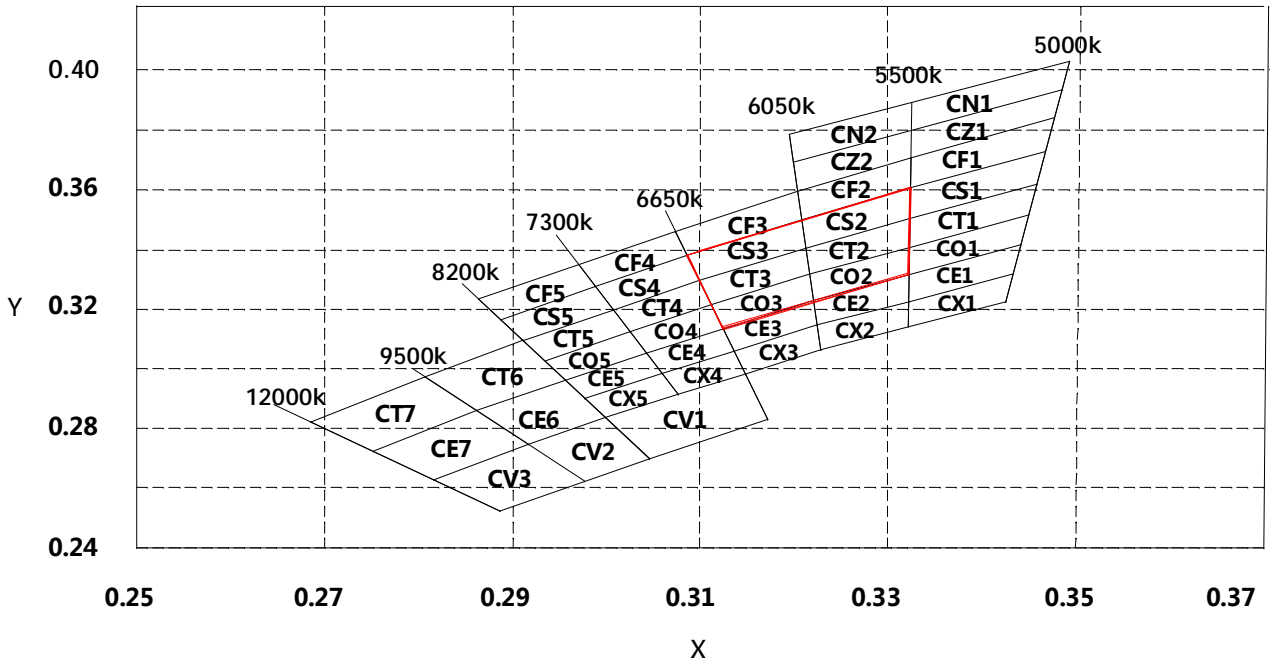

Note:  is high bin



Bin data:

| BIN CODE | CIE-X1 | CIE-Y1 | CIE-X2 | CIE-Y2 | CIE-X3 | CIE-Y3 | CIE-X4 | CIE-Y4 |
|----------|--------|--------|--------|--------|--------|--------|--------|--------|
| WF1 | 0.4889 | 0.4466 | 0.4742 | 0.4436 | 0.4677 | 0.4319 | 0.4817 | 0.4347 |
| WF2 | 0.4742 | 0.4436 | 0.4613 | 0.4400 | 0.4553 | 0.4284 | 0.4677 | 0.4319 |
| WF3 | 0.4613 | 0.4400 | 0.4489 | 0.4367 | 0.4435 | 0.4246 | 0.4553 | 0.4284 |
| WF4 | 0.4489 | 0.4367 | 0.4380 | 0.4330 | 0.4330 | 0.4206 | 0.4435 | 0.4246 |
| WF5 | 0.4380 | 0.4330 | 0.4267 | 0.4293 | 0.4223 | 0.4171 | 0.4330 | 0.4206 |
| WF6 | 0.4267 | 0.4293 | 0.4184 | 0.4261 | 0.4137 | 0.4138 | 0.4223 | 0.4171 |
| WS1 | 0.4817 | 0.4347 | 0.4677 | 0.4319 | 0.4615 | 0.4205 | 0.4749 | 0.4232 |
| WS2 | 0.4677 | 0.4319 | 0.4553 | 0.4284 | 0.4496 | 0.4171 | 0.4615 | 0.4205 |
| WS3 | 0.4553 | 0.4284 | 0.4435 | 0.4246 | 0.4383 | 0.4136 | 0.4496 | 0.4171 |
| WS4 | 0.4435 | 0.4246 | 0.4330 | 0.4206 | 0.4282 | 0.4097 | 0.4383 | 0.4136 |
| WS5 | 0.4330 | 0.4206 | 0.4223 | 0.4171 | 0.4180 | 0.4059 | 0.4282 | 0.4097 |
| WS6 | 0.4223 | 0.4171 | 0.4137 | 0.4138 | 0.4093 | 0.4020 | 0.4180 | 0.4059 |
| WT1 | 0.4749 | 0.4232 | 0.4615 | 0.4205 | 0.4556 | 0.4095 | 0.4682 | 0.4120 |
| WT2 | 0.4615 | 0.4205 | 0.4496 | 0.4171 | 0.4440 | 0.4063 | 0.4556 | 0.4095 |
| WT3 | 0.4496 | 0.4171 | 0.4383 | 0.4136 | 0.4334 | 0.4030 | 0.4440 | 0.4063 |
| WT4 | 0.4383 | 0.4136 | 0.4282 | 0.4097 | 0.4235 | 0.3993 | 0.4334 | 0.4030 |
| WT5 | 0.4282 | 0.4097 | 0.4180 | 0.4059 | 0.4139 | 0.3950 | 0.4235 | 0.3993 |
| WT6 | 0.4180 | 0.4059 | 0.4093 | 0.4020 | 0.4051 | 0.3906 | 0.4139 | 0.3950 |
| WO1 | 0.4682 | 0.4120 | 0.4556 | 0.4095 | 0.4498 | 0.3989 | 0.4618 | 0.4013 |
| WO2 | 0.4556 | 0.4095 | 0.4440 | 0.4063 | 0.4387 | 0.3958 | 0.4498 | 0.3989 |
| WO3 | 0.4440 | 0.4063 | 0.4334 | 0.4030 | 0.4285 | 0.3921 | 0.4387 | 0.3958 |
| WO4 | 0.4334 | 0.4030 | 0.4235 | 0.3993 | 0.4190 | 0.3886 | 0.4285 | 0.3921 |
| WO5 | 0.4235 | 0.3993 | 0.4139 | 0.3950 | 0.4099 | 0.3843 | 0.4190 | 0.3886 |
| WO6 | 0.4139 | 0.3950 | 0.4051 | 0.3906 | 0.4009 | 0.3796 | 0.4099 | 0.3843 |
| WE1 | 0.4618 | 0.4013 | 0.4498 | 0.3989 | 0.4442 | 0.3886 | 0.4555 | 0.3909 |
| WE2 | 0.4498 | 0.3989 | 0.4387 | 0.3958 | 0.4335 | 0.3857 | 0.4442 | 0.3886 |
| WE3 | 0.4387 | 0.3958 | 0.4285 | 0.3921 | 0.4238 | 0.3822 | 0.4335 | 0.3857 |
| WE4 | 0.4285 | 0.3921 | 0.4190 | 0.3886 | 0.4146 | 0.3785 | 0.4238 | 0.3822 |
| WE5 | 0.4190 | 0.3886 | 0.4099 | 0.3843 | 0.4060 | 0.3739 | 0.4146 | 0.3785 |
| WE6 | 0.4099 | 0.3843 | 0.4009 | 0.3796 | 0.3970 | 0.3689 | 0.4060 | 0.3739 |
| WX1 | 0.4555 | 0.3909 | 0.4442 | 0.3886 | 0.4388 | 0.3787 | 0.4495 | 0.3808 |



| | | | | | | | | |
|-----|--------|--------|--------|--------|--------|--------|--------|--------|
| WX2 | 0.4335 | 0.3857 | 0.4285 | 0.3758 | 0.4388 | 0.3787 | 0.4442 | 0.3886 |
| WX3 | 0.4335 | 0.3857 | 0.4238 | 0.3822 | 0.4193 | 0.3721 | 0.4285 | 0.3758 |
| WX4 | 0.4238 | 0.3822 | 0.4146 | 0.3785 | 0.4103 | 0.3682 | 0.4193 | 0.3721 |
| WX5 | 0.4146 | 0.3785 | 0.4060 | 0.3739 | 0.4023 | 0.3642 | 0.4103 | 0.3682 |
| WX6 | 0.4060 | 0.3739 | 0.3970 | 0.3689 | 0.3931 | 0.3587 | 0.4023 | 0.3642 |
| NF1 | 0.4184 | 0.4261 | 0.4058 | 0.4200 | 0.4019 | 0.4074 | 0.4137 | 0.4138 |
| NF2 | 0.4058 | 0.4200 | 0.3920 | 0.4121 | 0.3888 | 0.3996 | 0.4019 | 0.4074 |
| NF3 | 0.3920 | 0.4121 | 0.3770 | 0.4035 | 0.3745 | 0.3909 | 0.3888 | 0.3996 |
| NF4 | 0.3770 | 0.4035 | 0.3618 | 0.3945 | 0.3601 | 0.3818 | 0.3745 | 0.3909 |
| NF5 | 0.3618 | 0.3945 | 0.3479 | 0.3841 | 0.3469 | 0.3728 | 0.3601 | 0.3818 |
| NS1 | 0.4137 | 0.4138 | 0.4019 | 0.4074 | 0.3981 | 0.3960 | 0.4093 | 0.4020 |
| NS2 | 0.4019 | 0.4074 | 0.3888 | 0.3996 | 0.3857 | 0.3887 | 0.3981 | 0.3960 |
| NS3 | 0.3888 | 0.3996 | 0.3745 | 0.3909 | 0.3722 | 0.3799 | 0.3857 | 0.3887 |
| NS4 | 0.3745 | 0.3909 | 0.3601 | 0.3818 | 0.3586 | 0.3710 | 0.3722 | 0.3799 |
| NS5 | 0.3601 | 0.3818 | 0.3469 | 0.3728 | 0.3460 | 0.3620 | 0.3586 | 0.3710 |
| NT1 | 0.4093 | 0.4020 | 0.3981 | 0.3960 | 0.3944 | 0.3850 | 0.4051 | 0.3906 |
| NT2 | 0.3981 | 0.3960 | 0.3857 | 0.3887 | 0.3826 | 0.3781 | 0.3944 | 0.3850 |
| NT3 | 0.3857 | 0.3887 | 0.3722 | 0.3799 | 0.3699 | 0.3699 | 0.3826 | 0.3781 |
| NT4 | 0.3722 | 0.3799 | 0.3586 | 0.3710 | 0.3572 | 0.3609 | 0.3699 | 0.3699 |
| NT5 | 0.3586 | 0.3710 | 0.3460 | 0.3620 | 0.3450 | 0.3516 | 0.3572 | 0.3609 |
| NO1 | 0.4051 | 0.3906 | 0.3944 | 0.3850 | 0.3909 | 0.3743 | 0.4009 | 0.3796 |
| NO2 | 0.3944 | 0.3850 | 0.3826 | 0.3781 | 0.3797 | 0.3679 | 0.3909 | 0.3743 |
| NO3 | 0.3826 | 0.3781 | 0.3699 | 0.3699 | 0.3677 | 0.3603 | 0.3797 | 0.3679 |
| NO4 | 0.3699 | 0.3699 | 0.3572 | 0.3609 | 0.3558 | 0.3510 | 0.3677 | 0.3603 |
| NO5 | 0.3572 | 0.3609 | 0.3450 | 0.3516 | 0.3442 | 0.3415 | 0.3558 | 0.3510 |
| NE1 | 0.4009 | 0.3796 | 0.3909 | 0.3743 | 0.3875 | 0.3641 | 0.3970 | 0.3689 |
| NE2 | 0.3909 | 0.3743 | 0.3797 | 0.3679 | 0.3769 | 0.3579 | 0.3875 | 0.3641 |
| NE3 | 0.3797 | 0.3679 | 0.3677 | 0.3603 | 0.3656 | 0.3500 | 0.3769 | 0.3579 |
| NE4 | 0.3677 | 0.3603 | 0.3558 | 0.3510 | 0.3544 | 0.3416 | 0.3656 | 0.3500 |
| NE5 | 0.3558 | 0.3510 | 0.3442 | 0.3415 | 0.3433 | 0.3318 | 0.3544 | 0.3416 |
| NX1 | 0.3970 | 0.3689 | 0.3875 | 0.3641 | 0.3843 | 0.3531 | 0.3931 | 0.3587 |
| NX2 | 0.3875 | 0.3641 | 0.3769 | 0.3579 | 0.3742 | 0.3468 | 0.3843 | 0.3531 |
| NX3 | 0.3769 | 0.3579 | 0.3656 | 0.3500 | 0.3636 | 0.3388 | 0.3742 | 0.3468 |



| | | | | | | | | |
|-----|--------|--------|--------|--------|--------|--------|--------|--------|
| NX4 | 0.3656 | 0.3500 | 0.3544 | 0.3416 | 0.3531 | 0.3308 | 0.3636 | 0.3388 |
| NX5 | 0.3544 | 0.3416 | 0.3433 | 0.3318 | 0.3425 | 0.3225 | 0.3531 | 0.3308 |
| CZ1 | 0.3491 | 0.3978 | 0.3326 | 0.3831 | 0.3325 | 0.3706 | 0.3479 | 0.3841 |
| CN1 | 0.3502 | 0.4106 | 0.3326 | 0.3947 | 0.3326 | 0.3831 | 0.3491 | 0.3978 |
| CZ2 | 0.3326 | 0.3831 | 0.3325 | 0.3706 | 0.3204 | 0.3597 | 0.3198 | 0.3714 |
| CN2 | 0.3326 | 0.3947 | 0.3326 | 0.3831 | 0.3198 | 0.3714 | 0.3193 | 0.3823 |
| CF1 | 0.3479 | 0.3841 | 0.3325 | 0.3706 | 0.3324 | 0.3604 | 0.3469 | 0.3728 |
| CF2 | 0.3325 | 0.3706 | 0.3204 | 0.3597 | 0.3208 | 0.3501 | 0.3324 | 0.3604 |
| CF3 | 0.3204 | 0.3597 | 0.3073 | 0.3463 | 0.3087 | 0.3377 | 0.3208 | 0.3501 |
| CF4 | 0.3073 | 0.3463 | 0.2970 | 0.3354 | 0.2989 | 0.3276 | 0.3087 | 0.3377 |
| CF5 | 0.2970 | 0.3354 | 0.2862 | 0.3235 | 0.2887 | 0.3165 | 0.2989 | 0.3276 |
| CS1 | 0.3469 | 0.3728 | 0.3324 | 0.3604 | 0.3324 | 0.3505 | 0.3460 | 0.3620 |
| CS2 | 0.3324 | 0.3604 | 0.3208 | 0.3501 | 0.3213 | 0.3408 | 0.3324 | 0.3505 |
| CS3 | 0.3208 | 0.3501 | 0.3087 | 0.3377 | 0.3100 | 0.3294 | 0.3213 | 0.3408 |
| CS4 | 0.3087 | 0.3377 | 0.2989 | 0.3276 | 0.3008 | 0.3200 | 0.3100 | 0.3294 |
| CS5 | 0.2989 | 0.3276 | 0.2887 | 0.3165 | 0.2910 | 0.3096 | 0.3008 | 0.3200 |
| CT1 | 0.3460 | 0.3620 | 0.3324 | 0.3505 | 0.3323 | 0.3409 | 0.3450 | 0.3516 |
| CT2 | 0.3324 | 0.3505 | 0.3213 | 0.3408 | 0.3217 | 0.3318 | 0.3323 | 0.3409 |
| CT3 | 0.3213 | 0.3408 | 0.3100 | 0.3294 | 0.3112 | 0.3214 | 0.3217 | 0.3318 |
| CT4 | 0.3100 | 0.3294 | 0.3008 | 0.3200 | 0.3025 | 0.3126 | 0.3112 | 0.3214 |
| CT5 | 0.3008 | 0.3200 | 0.2910 | 0.3096 | 0.2933 | 0.3029 | 0.3025 | 0.3126 |
| CO1 | 0.3450 | 0.3516 | 0.3323 | 0.3409 | 0.3322 | 0.3317 | 0.3442 | 0.3415 |
| CO2 | 0.3323 | 0.3409 | 0.3217 | 0.3318 | 0.3221 | 0.3231 | 0.3322 | 0.3317 |
| CO3 | 0.3217 | 0.3318 | 0.3112 | 0.3214 | 0.3124 | 0.3136 | 0.3221 | 0.3231 |
| CO4 | 0.3112 | 0.3214 | 0.3025 | 0.3126 | 0.3043 | 0.3054 | 0.3124 | 0.3136 |
| CO5 | 0.3025 | 0.3126 | 0.2933 | 0.3029 | 0.2955 | 0.2965 | 0.3043 | 0.3054 |
| CE1 | 0.3442 | 0.3415 | 0.3322 | 0.3317 | 0.3322 | 0.3228 | 0.3433 | 0.3318 |
| CE2 | 0.3322 | 0.3317 | 0.3221 | 0.3231 | 0.3225 | 0.3147 | 0.3322 | 0.3228 |
| CE3 | 0.3221 | 0.3231 | 0.3124 | 0.3136 | 0.3136 | 0.3061 | 0.3225 | 0.3147 |
| CE4 | 0.3124 | 0.3136 | 0.3043 | 0.3054 | 0.3059 | 0.2985 | 0.3136 | 0.3061 |
| CE5 | 0.3043 | 0.3054 | 0.2955 | 0.2965 | 0.2977 | 0.2901 | 0.3059 | 0.2985 |
| CX1 | 0.3433 | 0.3318 | 0.3322 | 0.3228 | 0.3321 | 0.3141 | 0.3425 | 0.3225 |
| CX2 | 0.3322 | 0.3228 | 0.3225 | 0.3147 | 0.3229 | 0.3066 | 0.3321 | 0.3141 |



| | | | | | | | | |
|-----|--------|--------|--------|--------|--------|--------|--------|--------|
| CX3 | 0.3225 | 0.3147 | 0.3136 | 0.3061 | 0.3148 | 0.2987 | 0.3229 | 0.3066 |
| CX4 | 0.3136 | 0.3061 | 0.3059 | 0.2985 | 0.3076 | 0.2917 | 0.3148 | 0.2987 |
| CX5 | 0.3059 | 0.2985 | 0.2977 | 0.2901 | 0.2998 | 0.2840 | 0.3076 | 0.2917 |
| CV1 | 0.3148 | 0.2987 | 0.2998 | 0.2840 | 0.3045 | 0.2705 | 0.3172 | 0.2835 |
| CV2 | 0.2998 | 0.2840 | 0.2814 | 0.2632 | 0.2886 | 0.2528 | 0.3045 | 0.2705 |
| CT6 | 0.2910 | 0.3096 | 0.2807 | 0.2976 | 0.2863 | 0.2860 | 0.2955 | 0.2965 |
| CT7 | 0.2807 | 0.2976 | 0.2685 | 0.2826 | 0.2751 | 0.2726 | 0.2863 | 0.2860 |
| CE6 | 0.2955 | 0.2965 | 0.2863 | 0.2860 | 0.2916 | 0.2749 | 0.2998 | 0.2840 |
| CE7 | 0.2863 | 0.2860 | 0.2751 | 0.2726 | 0.2814 | 0.2632 | 0.2916 | 0.2749 |
| CX1 | 0.3433 | 0.3318 | 0.3322 | 0.3228 | 0.3321 | 0.3141 | 0.3425 | 0.3225 |
| CX2 | 0.3322 | 0.3228 | 0.3225 | 0.3147 | 0.3229 | 0.3066 | 0.3321 | 0.3141 |
| CX3 | 0.3225 | 0.3147 | 0.3136 | 0.3061 | 0.3148 | 0.2987 | 0.3229 | 0.3066 |
| CX4 | 0.3136 | 0.3061 | 0.3059 | 0.2985 | 0.3076 | 0.2917 | 0.3148 | 0.2987 |
| CX5 | 0.3059 | 0.2985 | 0.2977 | 0.2901 | 0.2998 | 0.2840 | 0.3076 | 0.2917 |
| CV1 | 0.3148 | 0.2987 | 0.2998 | 0.2840 | 0.3045 | 0.2705 | 0.3172 | 0.2835 |
| CV2 | 0.2998 | 0.2840 | 0.2814 | 0.2632 | 0.2886 | 0.2528 | 0.3045 | 0.2705 |
| CT6 | 0.2910 | 0.3096 | 0.2807 | 0.2976 | 0.2863 | 0.2860 | 0.2955 | 0.2965 |
| CT7 | 0.2807 | 0.2976 | 0.2685 | 0.2826 | 0.2751 | 0.2726 | 0.2863 | 0.2860 |
| CE6 | 0.2955 | 0.2965 | 0.2863 | 0.2860 | 0.2916 | 0.2749 | 0.2998 | 0.2840 |
| CE7 | 0.2863 | 0.2860 | 0.2751 | 0.2726 | 0.2814 | 0.2632 | 0.2916 | 0.2749 |

Lumilous flux(LM) BIN:

| BIN CODE | MIN | MAX | BIN CODE | MIN | MAX |
|----------|-----|-----|----------|-----|-----|
| Q1 | 60 | 70 | Q6 | 110 | 120 |
| Q2 | 70 | 80 | Q7 | 120 | 130 |
| Q3 | 80 | 90 | Q8 | 130 | 140 |
| Q4 | 90 | 100 | Q9 | 140 | 150 |
| Q5 | 100 | 110 | | | |

VF BIN:

| BIN CODE | MIN | MAX |
|----------|-----|-----|
| V7 | 2.8 | 3.0 |
| V8 | 3 | 3.2 |
| V9 | 3.2 | 3.4 |
| V10 | 3.4 | 3.6 |
| V11 | 3.6 | 3.8 |
| V12 | 3.8 | 4.0 |

Optical characteristics curves

Spectral Distribution

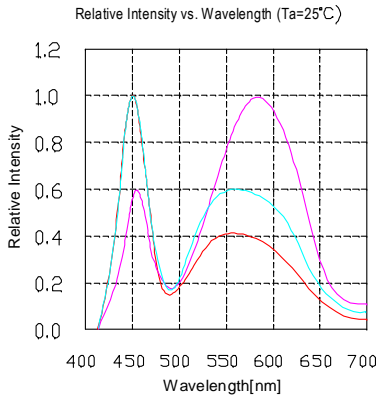

Forward Voltage vs. Forward Current (Ta=25°C)

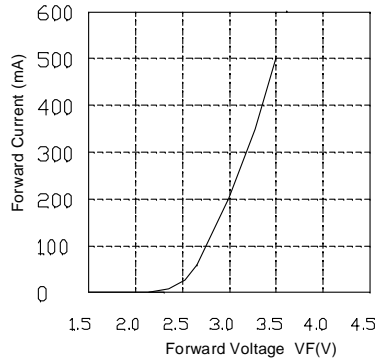

Relative Intensity vs. Forward Current (Ta=25°C)

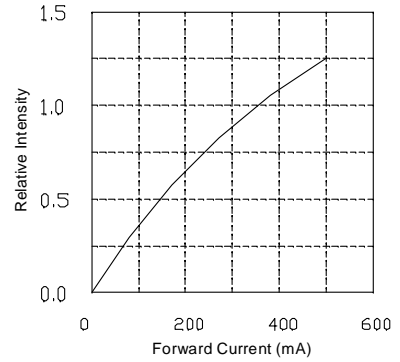

Relative Intensity vs. Ambient Temperature

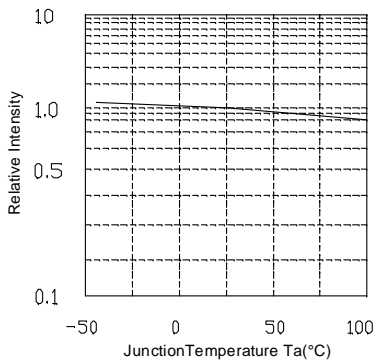

Derating

Ambient Temperature vs. Maximum Forward Current

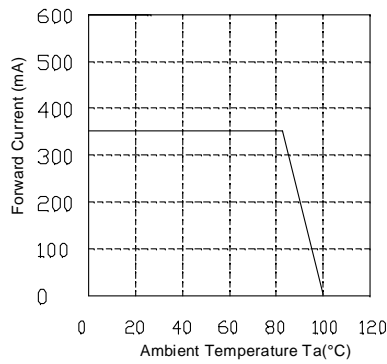

Forward Current vs. Chromaticity (Ta=25°C)

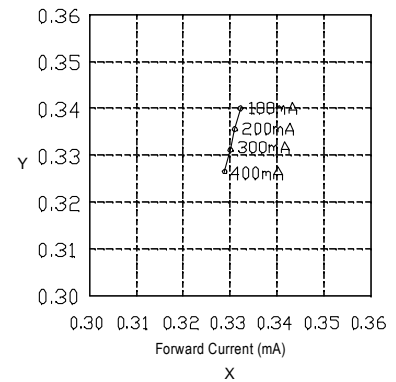

Forward Current vs. Chromaticity (Ta=25°C)
For warm white

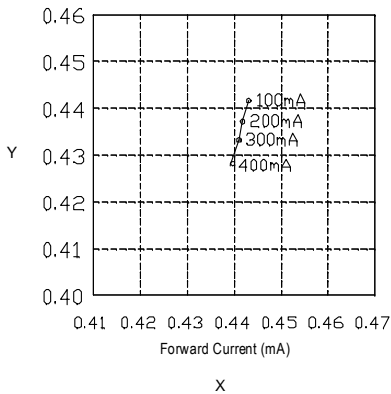
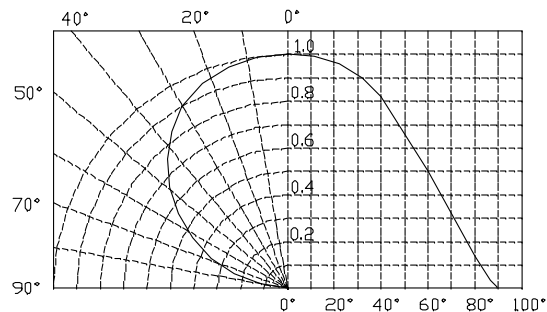

Diagram characteristics of radiation



Reflow profile

■ Soldering condition

- Recommended soldering conditions

| Reflow Soldering | | Hand Soldering | |
|------------------|------------------------------|----------------|----------------------------------|
| Pre-heat | 160~180°C | Temperature | 300°C Max. |
| Pre-heat time | 120 seconds Max. | Soldering time | 3 second Max. (one time only) |
| Peak temperature | 260°C Max. | | |
| Soldering time | 10 seconds Max. | | |
| Condition | Refer to Temperature-profile | | |

- After reflow soldering rapid cooling should be avoided

■ Temperature-profile (Surface of circuit board)

Use the following conditions shown in the figure.

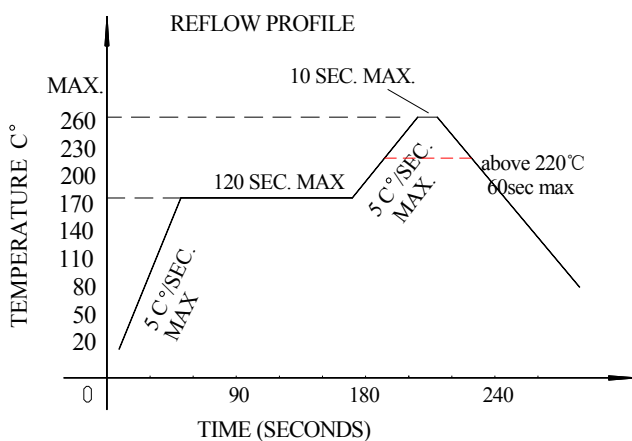

RECOMMEND PAD DESIGN (Units: mm)

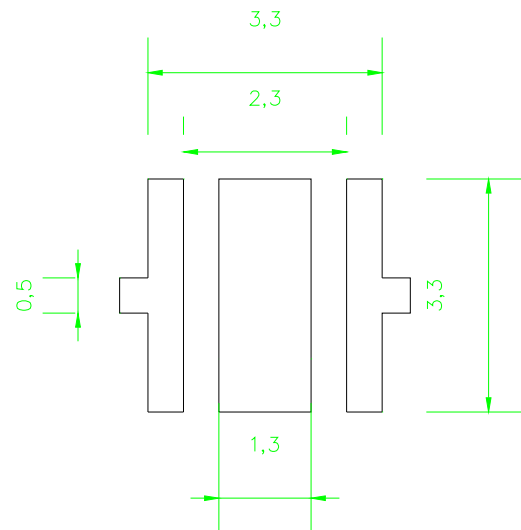

1. Reflow soldering should not be done more than two times
2. When soldering, do not put stress on the LEDs during heating

■ Soldering iron

1. When hand soldering, keep the temperature of the iron under 300°C, and at that temperature keep the time under 3 sec.
2. The hand soldering should be done only a time
3. The basic spec is ≤ 5 sec. when the temperature of 260°C, do not contact the resin when hand soldering



Reliability

(1) TEST ITEMS AND RESULTS

| Type | Test Item | Ref. Standard | Test Conditions | Note | Number of Damaged |
|------------------------|--|---------------|---|-----------|-------------------|
| Environmental Sequence | Resistance to Soldering Heat(Reflow Soldering) | JESD22-B106 | Tsld=260°C,10sec | 3 times | 0/22 |
| | Temperature Cycle | JESD22-A104 | -40°C 30min ↑↓5min 100°C 30min | 200 cycle | 0/22 |
| | Thermal Shock | JESD22-A106 | -40°C 15min ↑↓ 100°C 15min | 200 cycle | 0/22 |
| | High Temperature Storage | JESD22-A103 | T _a =100°C | 1000 hrs | 0/22 |
| | Low Temperature Storage | JESD22-A119 | T _a =-40°C | 1000 hrs | 0/22 |
| Operation Sequence | Life Test | JESD22-A108 | T _a =25°C I _F =350mA | 1000 hrs | 0/22 |
| | High Temperature Life Test | JESD22-A108 | T _a =85°C I _F =350mA | 1000 hrs | 0/22 |
| | High Humidity Heat Life Test | JESD22-A101 | 60°C RH=90% I _F =350mA | 1000 hrs | 0/22 |

(2) CRITERIA FOR JUDGING THE DAMAGE

| Item | Symbol | Test Conditions | Criteria for Judgement | |
|-----------------|--------|-----------------|------------------------|-------------|
| | | | Min. | Max. |
| Forward Voltage | VF | IF=350mA | - | U.S.L*)×1.1 |
| Reverse Current | IR | VR=5V | - | U.S.L*)×2.0 |
| Luminous flux | Φ | IF=350mA | L.S.L**)×0.7 | - |

U.S.L.: Upper Standard Level

L.S.L.: Lower Standard Level

Packaging Specifications

● Feeding Direction

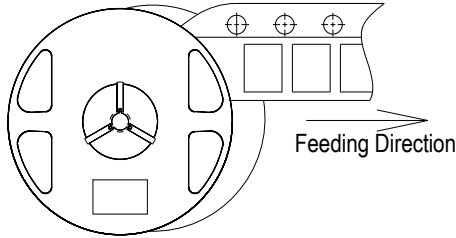

● Dimensions of Reel (Unit: mm)

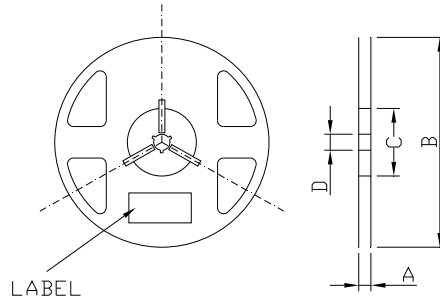

| | |
|---|------------|
| A | 12.4±0.1mm |
| B | 330±1mm |
| C | 100±1mm |
| D | 13.0±0.5mm |

● Dimensions of Tape (Unit: mm)

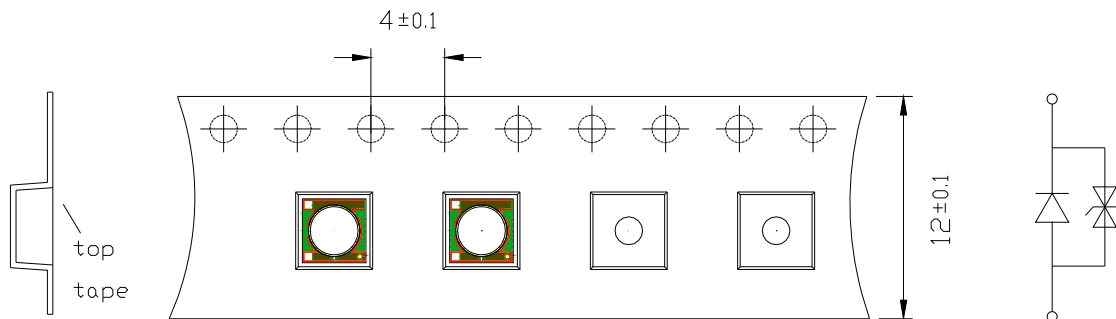

● Arrangement of Tape

Feeding Direction _____

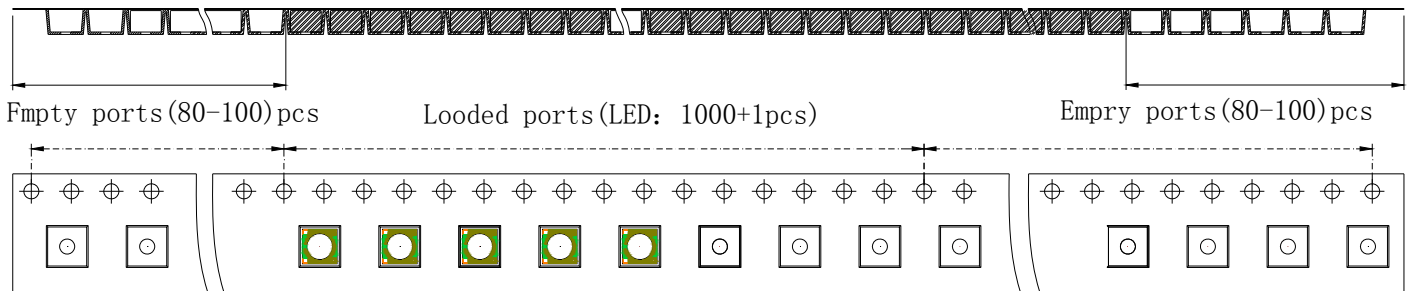



NOTES

1. Empty component pockets are sealed with top cover tape;
2. The maximum number of missing lamps is two;
3. The cathode is oriented towards the tape sprocket hole in accordance with ANSI/EIA RS-481 specifications.
4. 1000 pcs/ Reel.

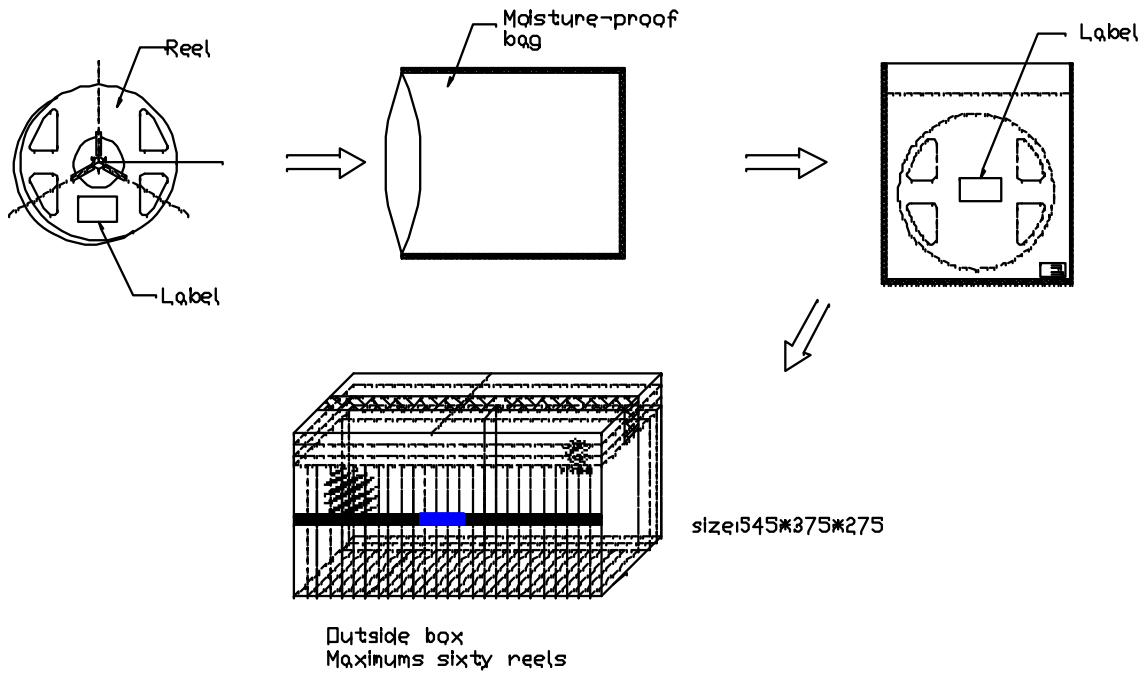
Packaging specifications



■ Label

| | |
|--|----------|
| PART NO: | |
|  | |
| LOT NO: | |
|  | |
| BIN CODE: | |
|  | |
| IV: | VF: X/Y: |
| QTY: | PCS |
| DATE: | |

CAUTIONS

Package specifications

Reeled products (numbers of products are 1.000pcs) packed in a seal off moisture-proof bag along with a desiccant one by one, Sixty moisture-proof bag of maximums are put the outside box (size: about 545mm x about 375mm x about 275mm) Together with buffer material, and it is packed. (Part No., Lot No., quantity should appear on the label on the moisture-proof bag, part No. And quantity should appear on the label on the cardboard box.) The number of the loading steps of outside box (cardboard box) has two steps.

Storage conditions

Before opening the package:

The LEDs should be kept at 30°C or less and 70%RH or less. The LEDs should be used within a year. When storing the LEDs, moisture proof packaging with absorbent material (silica gel) is recommended.

After opening the package:

The LEDs should be kept at 30°C or less and 50%RH or less. If unused LEDs remain, they should be stored in moisture proof packages, such as sealed containers with packages of moisture absorbent material (silica gel). It is also recommended to return the LEDs to the original moisture proof bag and to reseal the moisture proof bag again.